

Design EZ easy-e® Control Valve

Contents

Introduction	1
Scope of Manual	1
Description	1
Specifications	2
Installation	2
Maintenance	3
Packing Lubrication	5
Packing Maintenance	5
Replacing Packing	8
Trim Maintenance	10
Disassembly	10
Lapping Metal Seats on Valves with Plain and Extension Bonnets	12
Assembly	12
ENVIRO-SEAL® Bellows Seal and Bonnet ..	15
Replacing a Plain or Extension Bonnet with an ENVIRO-SEAL Bellows Seal (Stem/Bellows Assembly) and Bonnet ..	15
Replacing an Installed ENVIRO-SEAL Bellows Seal (Stem/Bellows Assembly) .	17
Purging the ENVIRO-SEAL Bellows Seal Bonnet	18
Parts Ordering	18
Parts Kits	19
Parts List	20

Introduction

Scope of Manual

This instruction manual includes installation, maintenance, and parts information for 0.5- through 4-inch Design EZ valves through Class 600 ratings. Refer to separate manuals for instructions covering the actuator and accessories.

No person may install, operate, or maintain a Design EZ valve without first • being fully trained and qualified in valve, actuator, and accessory installation, operation, and maintenance, and • carefully reading and understanding the contents of this manual. If you have any questions about these instructions, contact your Fisher® sales office before proceeding.



W8120A-1

Figure 1. Design EZ Valve with Type 657 Actuator and DVC6000 Digital Valve Controller

Description

Design EZ valves (figure 1) are globe-style with integral end connections, post guiding, and quick-change trim. These valves are used in chemical or hydrocarbon processing applications or in applications that require control of nonlubricating, viscous, or other hard-to-handle fluids.

Note

Neither Emerson™, Emerson Process Management, nor Fisher assume responsibility for the selection, use, or maintenance of any product. Responsibility for proper selection, use, and maintenance of any Fisher product remains solely with the purchaser and end-user.



Table 1. Specifications

<p>End Connection Styles</p> <p>Cast Iron Valves <i>Flanged:</i> Class 125 flat-face or 250 raised-face flanges per ASME B16.1 <i>Screwed:</i> Consistent with ASME B16.4</p> <p>Steel and Stainless Steel Valves <i>Flanged:</i> Class 150, 300, and 600 raised-face or ring-type joint flanges per ASME B16.5 <i>Screwed or Socket Welding:</i> Consistent with ASME B16.11 <i>Buttwelding:</i> All available ASME B16.25 schedules that are consistent with ASME B16.34</p> <p>Maximum Inlet Pressure⁽¹⁾</p> <p>Cast Iron Valves <i>Flanged:</i> Consistent with Class 125B or 250B per ASME B16.1 <i>Screwed:</i> Consistent with Class 250 per ASME B16.4</p> <p>Steel and Stainless Steel Valves <i>Flanged:</i> Consistent with Class 150, 300, or 600 per ASME B16.34</p>	<p><i>Screwed or Welding:</i> Consistent with Class 600 per ASME B16.34</p> <p>Shutoff Classifications per ANSI/FCI 70-2 and IEC 60534-4</p> <p>Metal Seats: Class IV is standard, Class V is optional PTFE Composition Seats: Class VI</p> <p>Flow Characteristics</p> <ul style="list-style-type: none"> ■ Equal percentage, ■ quick opening, and ■ linear <p>Flow Direction</p> <p>Up through the seat ring</p> <p>Approximate Weights</p> <p>0.5 and 0.75-Inch Valves: 9.1 kg (20 pounds) 1-Inch Valve: 11 kg (25 pounds) 1.5 Inch Valve: 18 kg (40 pounds) 2-Inch Valve: 36 kg (80 pounds) 3-Inch Valve: 54 kg (120 pounds) 4-Inch Valve: 75 kg (165 pounds)</p>
--	---

1. The pressure/temperature limits in this manual and any applicable standard or code limitation for valve should not be exceeded.

Specifications

Typical specifications for these valves are shown in table 1.

as required by government or accepted industry codes and good engineering practices.

Check with your process or safety engineer for any additional measures that must be taken to protect against process media.

If installing into an existing application, also refer to the **WARNING** at the beginning of the Maintenance section in this instruction manual.

Installation

WARNING

Always wear protective gloves, clothing, and eyewear when performing any installation operations to avoid personal injury.

Personal injury or equipment damage caused by sudden release of pressure may result if the valve assembly is installed where service conditions could exceed the limits given in table 1 or on the appropriate nameplates. To avoid such injury or damage, provide a relief valve for overpressure protection

CAUTION

When ordered, the valve configuration and construction materials were selected to meet particular pressure, temperature, pressure drop, and controlled fluid conditions. Responsibility for the safety of process media and compatibility of valve materials with process media rests solely with the purchaser and end-user. Since some body/trim

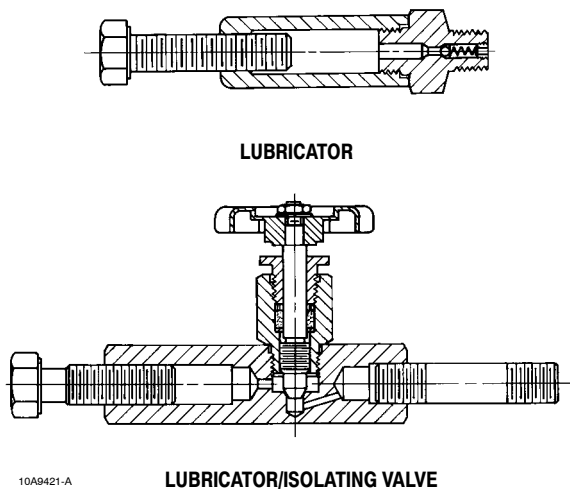

10A9421-A
AL5428-D
A0832-2/IL

Figure 2. Optional Packing Lubricator and Lubricator/Isolating Valve

material combinations are limited in their pressure drop and temperature ranges, do not apply any other conditions to the valve without first contacting your Fisher sales office.

1. Before installing the valve, inspect it and any associated equipment for damage and any foreign material. Make certain the valve interior is clean, that pipelines are free of foreign material, and that the valve is oriented so that pipeline flow is in the same direction as the arrow on the side of the valve.
2. The control valve assembly may be installed in any orientation unless limited by seismic criteria. However, the normal method is with the actuator vertical above the valve. Other positions may result in uneven valve plug and seat ring retainer wear, and improper operation. With some valves, the actuator may also need to be supported when it is not vertical. For more information, consult your Fisher sales office.
3. Use accepted piping and welding practices when installing the valve in the line. Internal elastomeric parts may stay in place during the welding procedure. For flanged valves, use a suitable gasket between the valve body flange and pipeline flanges.

Note

Depending on valve body materials used, post weld heat treating may be required. If so, damage to internal elastomeric and plastic parts, as well as internal metal parts is possible. Shrunk-fit pieces and threaded

connections may also loosen. In general, if post weld heat treating is to be performed, all trim parts should be removed. Contact your Fisher sales office for additional information.

4. With a leak-off bonnet construction, remove the pipe plugs (key 14) to hook up the leak-off piping. If continuous operation is required during inspection or maintenance, install a three-valve bypass around the control valve assembly.
5. If the actuator and valve are shipped separately, refer to the actuator mounting procedure in the appropriate actuator instruction manual.

⚠ WARNING

Personal injury could result from packing leakage. Valve packing was tightened before shipment; however, the packing might require some readjustment to meet specific service conditions. Check with your process or safety engineer for any additional measures that must be taken to protect against process media.

Valves with ENVIRO-SEAL® live-loaded packing or HIGH-SEAL™ Heavy-Duty live-loaded packing will not require this initial re-adjustment. See the Fisher instruction manuals titled ENVIRO-SEAL Packing System for Sliding-Stem Valves or Heavy-Duty Live-Loaded Packing System (as appropriate) for packing instructions. If you wish to convert your present packing arrangement to ENVIRO-SEAL packing, refer to the retrofit kits listed in the Parts Kits sub-section near the end of this manual.

Maintenance

Valve parts are subject to normal wear and must be inspected and replaced as necessary. Inspection and maintenance frequency depends on the severity of service conditions. This section includes instructions for packing lubrication, packing maintenance, trim maintenance, and ENVIRO-SEAL bellows seal replacement. All maintenance operations may be performed with the valve in the line.

⚠ WARNING

Avoid personal injury or property damage from sudden release of

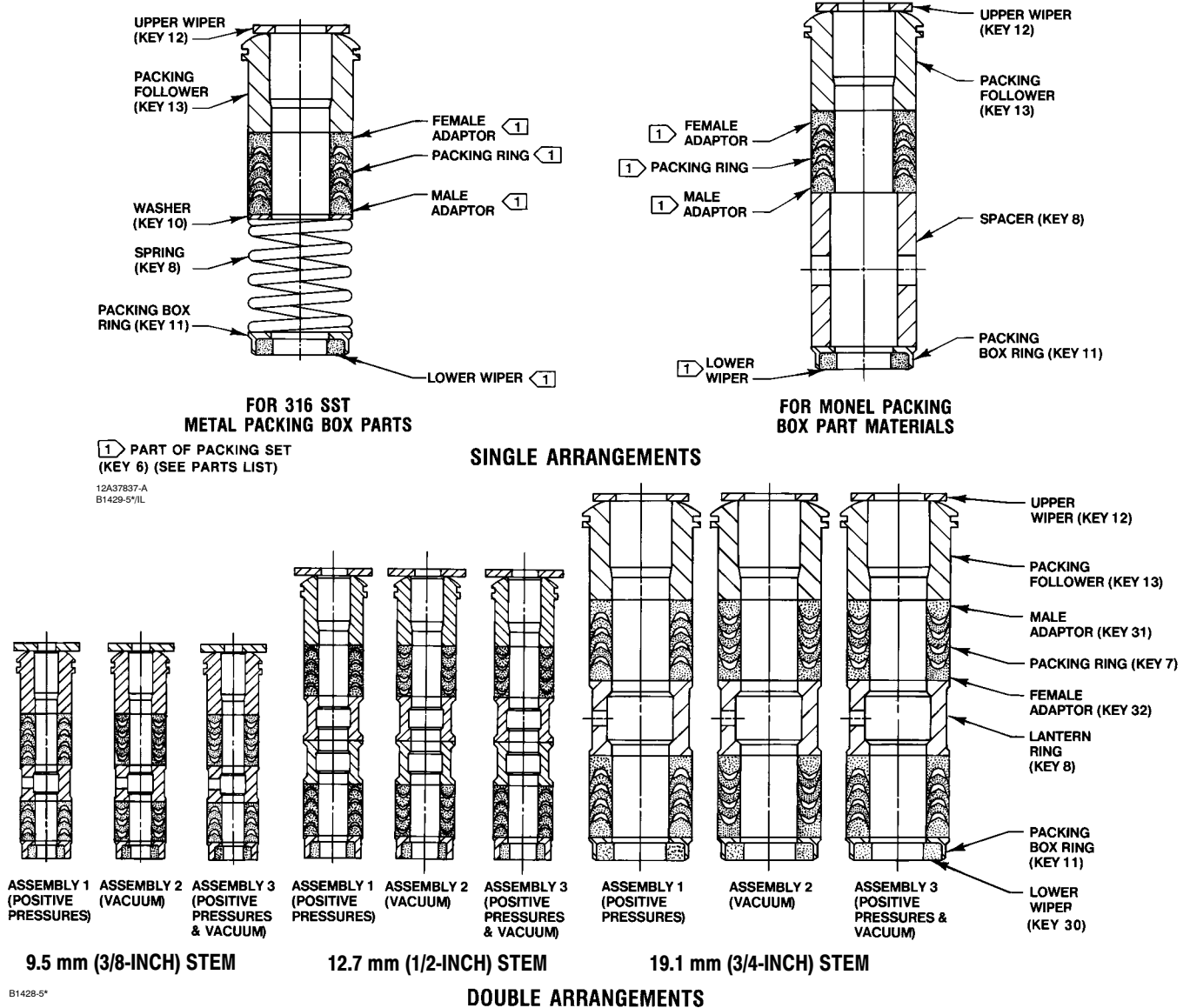

Figure 3. PTFE V-Ring Packing Arrangements for Plain and Extension Bonnets

process pressure or bursting of parts. Before performing any maintenance operations:

- Always wear protective gloves, clothing, and eyewear when performing any maintenance operations to avoid personal injury.
- Disconnect any operating lines providing air pressure, electric power, or a control signal to the actuator. Be sure the actuator cannot suddenly open or close the valve.

- Use bypass valves or completely shut off the process to isolate the valve from process pressure. Relieve process pressure from both sides of the valve. Drain the process media from both sides of the valve.

- Vent the pneumatic actuator loading pressure and relieve any actuator spring precompression.

- Use lock-out procedures to be sure that the above measures stay in effect while you work on the equipment.

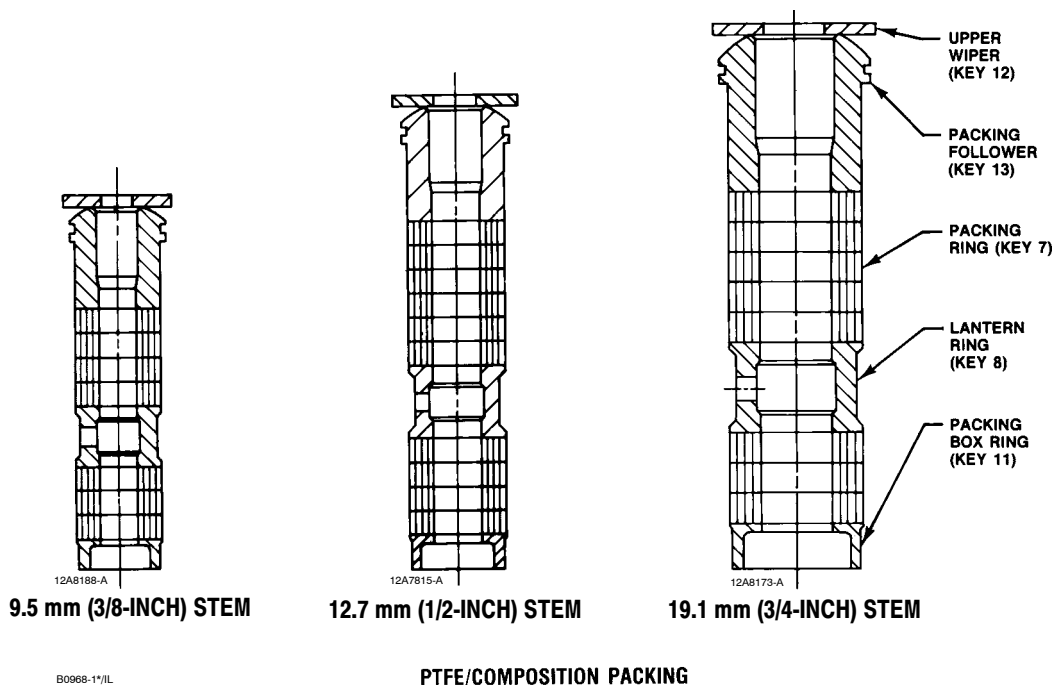

Figure 4. PTFE/Composition Packing Arrangements for Plain and Extension Bonnets

- The valve packing box may contain process fluids that are pressurized, even when the valve has been removed from the pipeline. Process fluids may spray out under pressure when removing the packing hardware or packing rings, or when loosening the packing box pipe plug.

- Check with your process or safety engineer for any additional measures that must be taken to protect against process media.

Note

Whenever a gasket seal is disturbed by removing or shifting gasketed parts, a new gasket should be installed upon reassembly. This is necessary to ensure a good gasket seal since the used gasket may not seal properly.

Note

If the valve has ENVIRO-SEAL or HIGH-SEAL live-loaded packing installed, refer to instruction manuals ENVIRO-SEAL Packing System for Sliding Stem Valves, Form 5306, or HIGH-SEAL Live Loaded Packing

System, Form 5263, for packing instructions. Figure 6 shows a typical HIGH-SEAL packing system. Figures 7 and 8 show typical ENVIRO-SEAL systems.

Packing Lubrication

Note

ENVIRO-SEAL or HIGH-SEAL packing does not require lubrication.

If an optional lubricator or lubricator/isolating valve (figure 2) is provided for PTFE/composition or other packings that require lubrication, it will be installed in an optional tapped hole in the bonnet. Use a good quality silicon-base lubricant. Packing used in oxygen service or in processes with temperatures over 260°C (500°F) should not be lubricated. To operate the lubricator, simply turn the cap screw clockwise to force the lubricant into the packing box. The lubricator/isolating valve must first be opened and then closed after lubrication is completed.

Packing Maintenance

This section covers PTFE V-ring, PTFE/composition, and graphite/ribbon packing as used in plain and extension bonnets. Unless otherwise indicated, key numbers refer to figure 3 for PTFE V-ring packing, figure 4 for PTFE/composition packing, and figure 5 for graphite ribbon/filament packing.

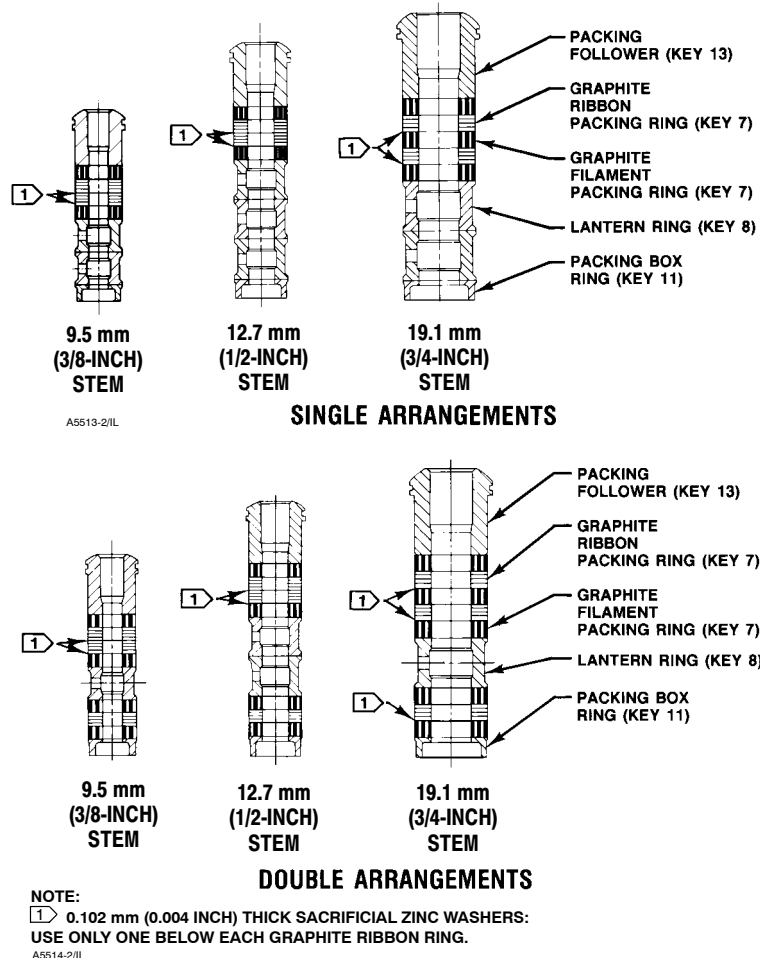

Figure 5. Graphite Ribbon/Filament Packing Arrangements for Plain and Extension Bonnets

For spring-loaded single PTFE V-ring packing, the spring (key 8, figure 3) maintains a sealing force on the packing. If leakage is noted around the packing follower (key 13, figure 3), check to be sure the shoulder on the packing follower is touching the bonnet. If the shoulder is not touching the bonnet, tighten the packing flange nuts (key 5, figure 11), until the shoulder is against the bonnet. If leakage cannot be stopped in this manner, proceed to the Replacing Packing procedure.

If there is unacceptable packing leakage with other than spring-loaded packing, first try to limit the leakage and establish a stem seal by tightening the packing flange nuts.

If the packing is relatively new and tight on the stem, and if tightening the packing flange nuts does not stop the leakage, the valve stem may be worn or nicked so that a seal cannot be made. The surface finish of a valve stem is critical for making a good packing seal. If the leakage comes from the outside diameter of the packing, the leakage may be caused by nicks or scratches around the packing box wall. If performing any of the following procedures, inspect the valve stem and packing box wall for nicks and scratches.

An illustration of a HIGH-SEAL live-loaded packing system is shown in figure 6. Illustrations of ENVIRO-SEAL live-loaded packing systems are shown in figures 7, 8, and 9.

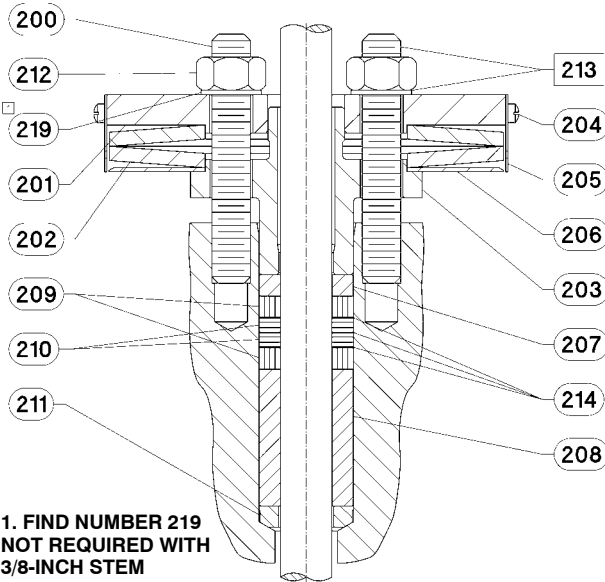

1. FIND NUMBER 219
NOT REQUIRED WITH
3/8-INCH STEM

39B4153-A

Figure 6. Typical HIGH-SEAL Graphite ULF Packing System

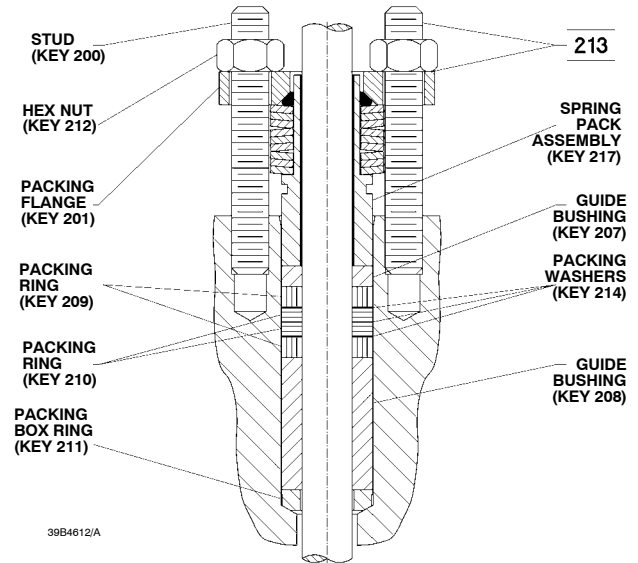

39B4612/A

Figure 8. Typical ENVIRO-SEAL Packing System with Graphite ULF Packing

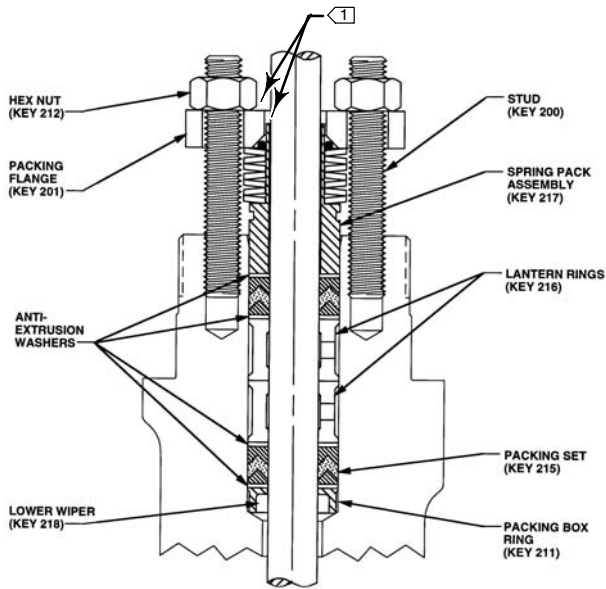

NOTE:

1 FOR PTFE PACKING, TIGHTEN THE PACKING BOX HEX NUTS UNTIL THE TOP OF THE FLANGE IS EVEN WITH THE TOP OF THE SLEEVE ON THE FOLLOWER (SPRING PACK ASSEMBLY).

A6297/L

Figure 7. Typical ENVIRO-SEAL® Packing System with PTFE Packing

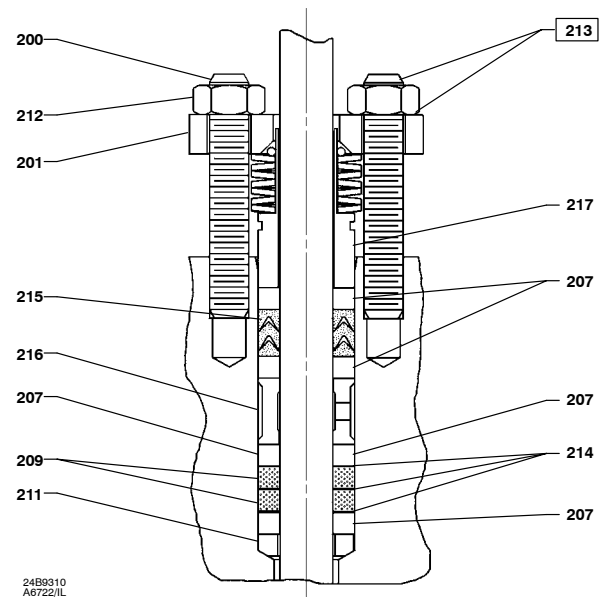

24B8310
A6722/JL

Figure 9. Typical ENVIRO-SEAL® Packing System with Duplex Packing

EZ Valve

Table 2. Body-to-Bonnet Torque Guidelines

VALVE SIZE, INCHES	TORQUES ⁽¹⁾			
	Bolt Material			
	SA193-B7		SA193-B8M ⁽²⁾	
Design EZ	N•m	Lbf•ft	N•m	Lbf•ft
1 or smaller	129	95	64	47
1.5 or 2	96	71	45	33
3	169	125	88	65
4	271	200	156	115

1. Determined from laboratory tests.
2. SA193-B8M annealed.

Replacing Packing



WARNING

Observe the warning at the start of the Maintenance section.

This section covers replacing packing used in plain and extension bonnets. PTFE V-ring packing is shown in figure 3, PTFE/composition packing is shown in figure 4, and graphite/ribbon packing is shown in figure 5.

1. Isolate the control valve from the line pressure, release pressure from both sides of the valve body, and drain the process media from both sides of the valve. If using a power actuator, also shut off all pressure lines to the power actuator, and release all pressure from the actuator. Use lock-out procedures to be sure that the above measures stay in effect while you work on the equipment.
2. Disconnect the operating lines from the actuator and any leak-off piping from the bonnet. Disconnect the stem connector and then remove the actuator from the valve by unscrewing the yoke locknut (key 15, figure 11).



WARNING

To avoid personal injury or property damage caused by uncontrolled movement of the bonnet, loosen the bonnet by following the instructions in the next step. Do not remove a stuck bonnet by pulling on it with equipment that can stretch or store energy in any other manner. The sudden release of stored energy can cause uncontrolled movement of the bonnet. If the seat ring retainer sticks to the bonnet, proceed carefully with bonnet removal.

Note

The following step also provides additional assurance that the valve body fluid pressure has been relieved.

3. Hex nuts (key 16, figure 11) attach the bonnet to the valve. Loosen these nuts or cap screws approximately 3 mm (1/8-inch). Then loosen the body-to-bonnet gasketed joint by either rocking the bonnet or prying between the bonnet and valve body. Work the prying tool around the bonnet until the bonnet loosens.
4. Loosen the packing flange nuts (key 5, figure 11) so that the packing is not tight on the valve stem. Remove any travel indicator parts and stem locknuts from the valve stem threads.

CAUTION

Avoid damaging the seating surface caused by the valve plug and stem assembly dropping from the bonnet after being lifted part way out. When lifting the bonnet, temporarily install a valve stem locknut on the valve stem. This locknut will prevent the valve plug and stem assembly from dropping out of the bonnet.

5. Completely remove the cap screws (not shown) or hex nuts (key 16, figure 12) that bolt the bonnet and valve body together and carefully lift the bonnet off.
6. Remove the locknut and separate the valve plug and stem from the bonnet. Set the parts on a protective surface to prevent damage to gasket or seating surfaces.
7. Remove the bonnet gasket (key 10, figure 12) and cover the opening in the valve to protect the gasket surface and to prevent foreign material from getting into the valve body cavity.
8. Remove the packing flange nuts, packing flange, upper wiper, and packing follower (keys 5, 3, 12, and

13, figure 11). Carefully push out all the remaining packing parts from the valve side of the bonnet using a rounded rod or other tool that will not scratch the packing box wall. Clean the packing box and the metal packing parts.

9. Inspect the valve stem threads and the packing box surfaces for any sharp edges which might cut the packing. Scratches or burrs could cause packing box leakage or damage to the new packing. If the surface condition cannot be improved by light sanding, replace the damaged parts.

10. Remove the covering protecting the valve cavity and install a new bonnet gasket (key 10, figure 12), making sure the gasket seating surfaces are clean and smooth. Then slide the bonnet over the stem and onto the stud bolts (key 15, figure 12), or onto the valve cavity if cap screws (not shown) are used instead.

Note

Proper performance of the tightening procedures in step 11 compresses the spiral wound gasket (key 12, figure 12) enough to both load and seal the seat ring gasket (key 13, figure 12). The tightening procedures also compresses the outer edge of the bonnet gasket (key 10, figure 12) enough to seal the body-to-bonnet joint.

The accepted bolting procedures referred to in step 11 include—but are not limited to—ensuring that bolting threads are clean, and evenly tightening the cap screws, or the nuts onto the studs, in a crisscross pattern. Because of the boltup characteristics of spiral wound gaskets, tightening one cap screw or nut may loosen an adjacent cap screw or nut. Repeat the crisscross tightening pattern several times until each cap screw or nut is tight and the body-to-bonnet seal is made. When the operating temperature has been reached, perform this torquing procedure once again.

11. Install bolting, using accepted bolting procedures during tightening so that the body-to-bonnet joint can withstand test pressures and application service conditions. The bolt torques in table 2 may be used as guidelines unless accepted bolting procedures dictate otherwise.

12. Install new packing and the metal packing box parts according to the appropriate arrangement in figure 3, 4, or 5. If split-ring packing is being added, alternate the position of the splits to avoid a leak path. Place a smooth-edged pipe over the valve stem and gently tap each soft packing part into the packing box, being sure that air is not trapped between adjacent soft parts.

Installation of graphite ribbon packing requires special care to avoid trapping air between the rings. Start with only one ring at a time without forcing the top of the packing ring below the bottom of the entrance chamfer of the packing box. Thus, when a ring is added, the stack should not be pushed into the cavity more than the thickness of the added ring.

13. Slide the packing follower, upper wiper, and packing flange (keys 13, 12, and 3, figure 11) into position. Lubricate the packing flange studs (key 4, figure 11) and the faces of the packing flange nuts (key 5, figure 11). Install the packing flange nuts.

Note

The torque values discussed in step 14 and shown in table 3 are recommended guidelines only and are presented as a starting point for this procedure. Tightening the packing flange nuts to a torque value that exceeds the table guidelines, in order to obtain a seal, may indicate other problems.

14. **For spring-loaded PTFE V-ring packing,** tighten the packing flange nuts until the shoulder on the packing follower (key 13, figure 11) contacts the bonnet.

For graphite packing, tighten the packing flange nuts to the maximum recommended torque shown in table 3. Then, loosen the packing flange nuts, and retighten them to the recommended minimum torque shown in table 3.

For other packing types, tighten the packing flange nuts alternately in small equal increments until one of the nuts reaches the minimum recommended torque shown in table 3. Then, tighten the remaining flange nuts until the packing flange is level and at a 90-degree angle to the valve stem.

For ENVIRO-SEAL or HIGH-SEAL live-loaded packing, refer to the note at the beginning of the Maintenance section on page 5 of this manual.

15. Mount the actuator on the valve body and reconnect the actuator and valve stem according to the procedure in the appropriate actuator instruction manual.

EZ Valve

Table 3. Recommended Torque for Packing Flange Nuts
(Not for Spring-Loaded Packing)

VALVE STEM DIAMETER		CLASS	GRAPHITE TYPE PACKING				PTFE TYPE PACKING			
			Minimum Torque		Maximum Torque		Minimum Torque		Maximum Torque	
mm	Inches		N•m	Lbf•in	N•m	Lbf•in	N•m	Lbf•in	N•m	Lbf•in
9.5	3/8	125, 150	3	27	5	40	1	13	2	19
		250, 300	4	36	6	53	2	17	3	26
		600	6	49	8	73	3	23	4	35
12.7	1/2	125, 150	5	44	8	66	2	21	4	31
		250, 300	7	59	10	88	3	28	5	42
		600	9	81	14	122	4	39	7	58
19.1	3/4	125, 150	11	99	17	149	5	47	8	70
		250, 300	15	133	23	199	7	64	11	95
		600	21	182	31	274	10	87	15	131

seat ring retainer is critical for smooth operation of the valve plug.

The seating surfaces of the valve plug and seat ring (keys 2 and 9) are critical for proper shutoff.

Protect these parts accordingly while disassembling the trim. Gasket selection criteria is provided on page 32 of this instruction manual.

2. Packing parts can be removed if desired. Replace these parts as described in the Replacing Packing procedure.

Valves with Plain or Extension Bonnets

Perform the following steps to remove the valve trim.

1. Lift the valve plug and stem assembly [or the plug guide, disk retainer, and disk (keys 27, 28, and 29, figure 13) if used], out of the valve body and set it on a protective surface.

Note

With some valve plug sizes and configurations, the seat ring retainer and bushing assembly (keys 3 and 26, figures 12 and 13) will come out of the valve body with the valve plug and stem assembly, and in other valve plug sizes and configurations, the valve plug or tip will slide through the seat ring retainer and bushing assembly, leaving the retainer and bushing assembly in the valve body.

2. With the valve plug and stem assembly out of the valve, either slide the seat ring retainer and bushing assembly (keys 3 and 26), and gaskets and shim (keys 10, 12, and 25) up over the valve plug and stem or lift the seat ring retainer and bushing assembly and associated gaskets and shim out of the valve body. If the valve plug is to be reused, protect the valve plug seating surface to prevent scratches.

3. For valves with metal seats, drive out the pin (key 8) and unscrew the valve stem (key 7) from the valve plug (key 2).

4. For valves with 0.25 and 0.375-inch ports and composition seats, refer to figure 13. Drive out the pin (key 8) and unscrew the valve stem (key 7) from the valve plug guide (key 27). Unscrew the disk retainer (key 28) from the valve plug guide. Remove the disk (key 29) from the valve plug tip (key 30).

For valves with 0.5 through 2-inch ports and composition seats, refer to figure 13. Drive out the

Trim Maintenance



WARNING

Observe the warning at the start of the Maintenance section.

This procedure describes how the valve trim can be completely disassembled. When inspection or repairs are required, perform only those steps necessary to accomplish the task.

Disassembly

Except where indicated, key numbers referenced in the following steps are found in figure 12.

1. Remove the actuator and the bonnet according to steps 1 through 6 of the Replacing Packing procedure of the Maintenance section.



WARNING

Avoid personal injury or property damage from valve or packing leakage.

Any damage to the gasket sealing surfaces could cause the valve to leak.

The surface finish of the valve stem (key 7) is critical for making a good packing seal. The inside surface of the

pin (key 8) and unscrew the valve stem (key 7) from the valve plug guide (key 27). Drive out pin (key 31) and unscrew the tip (key 30) from the valve plug guide. Remove the disk (key 29) from the valve plug guide.

For valves with 3 and 4-inch ports and composition seats, refer to figure 13. Drive out the pin (key 8) and unscrew the valve stem from the valve plug guide (key 27). Remove the cap screw (key 32) to remove the tip (key 30) from the valve plug guide. Remove the disk (key 29).

5. Remove the seat ring and seat ring gasket (keys 9 and 13).

6. Inspect parts for wear or damage that would prevent proper operation of the valve. Replace or repair trim parts according to the following Lapping Metal Seats or Assembly procedure as appropriate.

Valves with ENVIRO-SEAL Bellows Seal Bonnets

Perform the following steps to remove the valve trim.

1. Lift the stem/bellows assembly with valve plug attached [or the plug guide, disk retainer, and disk (keys 27, 28, and 29, figure 13) if used], seat ring retainer and gaskets out of the valve body and set them on a protective surface.

Note

With some valve plug sizes and configurations, the seat ring retainer and bushing assembly (keys 3 and 26, figures 12 and 13) will come out of the valve body with the stem/bellows, and in other valve plug sizes and configurations, the valve plug or tip will slide through the seat ring retainer and bushing assembly, leaving the retainer and bushing assembly in the valve body.

2. If the seat ring retainer and bushing assembly (keys 3 and 26) stayed in the valve, lift them out along with gaskets and shim (keys 10, 12, and 25).

3. If the seat ring retainer and bushing assembly (keys 3 and 26) came out of the valve with the stem/bellows assembly, move the seat ring retainer and bushing assembly against the shoulder of the valve plug (key 2) or valve plug guide (key 27, figure 13) to provide access to the pin (key 36, figure 11).

VALVE STEM		BOLT TORQUE		DRILL SIZE, INCH	D DIMENSION	
mm	Inch	N•m	Lbf•ft		mm	Inch
9.5	3/8	40-47	25-35	3/32	16	0.625
12.7	1/2	81-115	60-85	1/8	19	0.75
19.0	3/4	237-339	175-250	3/16	25	1

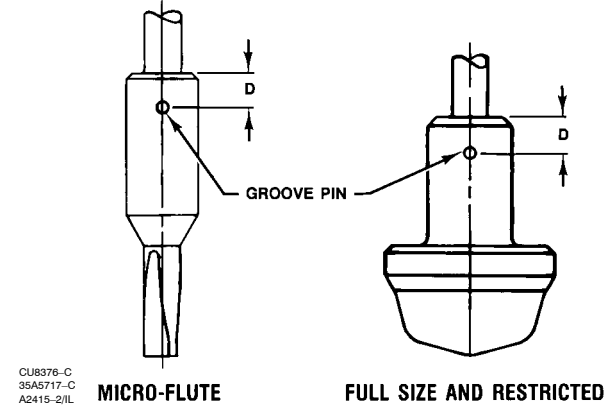

Figure 10. Bolt Torque for Plug/Stem Connection and Plug/Adaptor Connection and Pin Replacement

4. Place the stem/bellows assembly and valve plug or valve plug guide in a soft-jaw chuck or other type of vise so that the jaws grip a portion of the valve plug or valve plug guide that is not a seating or guiding surface. Drive out the pin (key 36, figure 11).

5. Remove the stem/bellows assembly from the soft-jaw chuck or vise. Place a wrench on the flat areas on the valve stem just below the threads for the actuator/stem connection to keep the stem from turning. Then, unscrew the adaptor (key 24, figure 11), which also includes the valve plug (key 2) or valve plug guide (key 27, figure 13), from the stem/bellows assembly (key 20, figure 11).

6. Remove the seat ring retainer and bushing assembly (keys 3 and 26) by sliding it over the adaptor. If the valve plug is to be reused, protect the valve plug seating surface to prevent scratches.

7. **For valves with metal seats,** drive out the pin (key 8) and unscrew the adaptor (key 24, figure 11) from the valve plug (key 2).

8. **For valves with 0.25 and 0.375-inch ports and composition seats, refer to figure 13.** Drive out the pin (key 8) and unscrew the adaptor (key 24, figure 11) from the valve plug guide (key 27). Unscrew the disk retainer (key 28) from the valve plug guide. Remove the disk (key 29) from the valve plug tip (key 30).

For valves with 0.5 through 2-inch ports and composition seats, refer to figure 13. Drive out the pin (key 8) and unscrew the adaptor (key 24, figure 11) from the valve plug guide (key 27). Drive out the pin (key 31) and unscrew the tip (key 30)

EZ Valve

from the valve plug guide. Remove the disk (key 29) from the valve plug guide.

For valves with 3 and 4-inch ports and composition seats, refer to figure 13. Drive out the pin (key 8) and unscrew the adaptor (key 24, figure 11) from the valve plug guide (key 27). Remove the cap screw (key 32) to remove the tip (key 30) from the valve plug guide. Remove the disk (key 29).

9. Remove the seat ring and seat ring gasket (keys 9 and 13).

10. Inspect parts for wear or damage that would prevent proper operation of the valve. Replace or repair trim parts according to the following Assembly procedure as appropriate.

Lapping Metal Seats on Valves with Plain and Extension Bonnets

CAUTION

To avoid damaging the ENVIRO-SEAL Bellows Seal Bonnet assembly, do not attempt to lap the metal seating surfaces on valves with ENVIRO-SEAL bellows seal bonnets. The design of the bonnet assembly prevents rotation of the stem and any forced lapping rotation will damage internal components of the ENVIRO-SEAL Bellows Seal bonnet.

With metal-seat constructions, seating surfaces of the valve plug and seat ring (key 2, figure 12) can be lapped for improved shutoff. (Deep nicks should be machined out rather than ground out.) Use a good quality lapping compound of a mixture of 280 to 600-grit. Apply the compound to the bottom of the valve plug.

Assemble the valve to the extent that the seat ring retainer is in place and the bonnet is bolted to the valve body. A simple handle can be made from a piece of strap iron locked to the valve plug stem with nuts. Rotate the handle alternately in each direction to lap the seats. After lapping, remove the bonnet and clean the seat surfaces. Completely assemble as described in the assembly portion of the Trim Maintenance procedure and test the valve for shutoff. Repeat the lapping procedure if leakage is still excessive.

Assembly

This procedure assumes that all the trim and associated gaskets were removed from the valve body. If these parts were not all removed, start the assembly procedure at the appropriate step. Except where indicated, key numbers referenced in the following steps are found in figure 12.

Valves with Plain or Extension Bonnets

Perform the following steps to assemble and install the trim.

CAUTION

To avoid weakening the stem that may cause failure in service, never reuse an old stem with a new valve plug. Using an old stem with a new plug requires drilling a new pin hole in the stem, which will weaken the stem. However, a used valve plug may be reused with a new stem.

1. **For valves with metal seats,** screw the valve stem (key 7) into the valve plug (key 2). Tighten to the torque value given in figure 10. Refer to figure 10 to select the proper drill size. Drill through the stem using the hole in the valve plug as a guide. Remove any chips or burrs and drive in a new pin (key 8) to lock the assembly.
2. **For valves with 0.25 and 0.375-inch ports and composition seats, refer to figure 13.** Place the disk (key 29) on the valve plug tip (key 30). Place the disk retainer (key 28) over the disk, and then thread the disk retainer onto the valve plug guide (key 27).

CAUTION

To avoid failure in service for valves with 0.5 through 1-inch ports and composition seats, never reuse an old valve plug guide with a new valve plug tip. Using an old valve plug guide with a new plug tip requires drilling a new pin hole in the valve plug guide, which will weaken the guide. However, a used valve plug tip may be reused with a new valve plug guide.

For valves with 0.5 through 1-inch ports and composition seats, refer to figure 13. Insert the disk (key 29) in the valve plug guide (key 27). Screw the tip (key 30) onto the valve plug guide to clamp the

disk in place. Using a 3/32-inch bit, drill through the valve plug guide using the hole in the tip as a drilling guide. Remove any chips or burrs and drive in a new pin (key 31).

CAUTION

To avoid failure in service for valves with 1.5 and 2-inch ports and composition seats, never reuse an old valve plug tip with a new valve plug guide. Using an old valve plug tip with a new valve plug guide requires drilling a new pin hole in the valve plug tip which will weaken the tip. However, a used valve plug guide may be reused with a new valve plug tip.

For valves with 1.5 and 2-inch ports and composition seats, refer to figure 13. Insert the disk (key 29) in the valve plug guide (key 27). Screw the tip (key 30) into the valve plug guide to clamp the disk in place. Using a 3/32-inch bit, drill through the valve plug tip using the hole in the valve plug guide as a drilling guide. Remove any chips or burrs and drive in a new pin (key 31).

For valves with 3 and 4-inch ports and composition seats, refer to figure 13. Insert the disk (key 29) in the valve plug guide (key 27). Place the tip (key 30) against the valve plug guide to clamp the disk in place. Insert the cap screw (key 32) through the tip and thread it into valve plug guide to secure the tip to the valve plug guide.

CAUTION

To avoid failure in service, never reuse an old stem with a new valve plug guide. Using an old stem with a new valve plug guide requires drilling a new pin hole in the stem, which will weaken the stem. However, a used valve plug guide may be reused with a new stem except for valves with 0.5 through 1-inch ports and composition seats (see to figure 13). For these constructions, a used valve plug guide should only be used if the tip is reused.

3. **For all valves with composition seats,** screw the valve stem (key 7) into the valve plug guide (key 27, figure 13). Tighten to the torque value given in figure 10. Refer to figure 10 to select the proper drill

size. Drill through the stem, using the hole in the valve plug guide as a drilling guide. Remove any chips or burrs and drive in a new pin (key 8) to lock the assembly.

4. Install the seat ring gasket (key 13), and replace the seat ring (key 9).

Note

With some valve plug sizes and configurations, the valve plug or tip will slide through the seat ring retainer and bushing assembly (keys 3 and 26), and in other configurations it won't.

5. If the valve plug (key 2) or valve plug tip (key 30, figure 13) will not slide through the seat ring retainer and bushing assembly (keys 3 and 26), proceed as follows:

a. Place the seat ring retainer and bushing assembly (keys 3 and 26) over the stem of valve plug and stem assembly or over the stem of the valve plug guide and stem assembly.

b. Install the seat ring retainer and bushing assembly, which also includes the valve plug and stem assembly or valve plug guide and stem assembly, on the top of the seat ring, ensuring that the seat ring retainer slips onto the seat ring properly. Any rotation orientation of the seat ring retainer with respect to the valve body is acceptable.

c. Place the spiral wound gasket, shim, and bonnet gasket (keys 12, 25, and 10) on the shoulder of the seat ring retainer.

6. If the valve plug (key 2) or the valve plug tip (key 30, figure 13) will slide through the seat ring retainer and bushing assembly (keys 3 and 26), proceed as follows:

a. Install the seat ring retainer and bushing assembly on the top of the seat ring, ensuring that the seat ring retainer slips onto the seat ring properly. Any rotation orientation of the seat ring retainer with respect to the valve body is acceptable.

b. Place the spiral wound gasket, shim, and bonnet gasket (keys 12, 25, and 10) on the shoulder of the seat ring retainer.

c. Slide the valve plug and stem assembly or the valve plug guide and stem assembly into the seat ring retainer and bushing assembly (keys 3 and 26).

EZ Valve

7. Mount the bonnet on the valve body and complete the assembly according to steps 10 through 15 of the Replacing Packing procedure, omitting steps 12 and 13 if new packing is not being installed, and being sure to observe the note prior to step 11.

Valves with ENVIRO-SEAL Bellows Seal Bonnets

Perform the following steps to assemble and install the trim.

1. **For valves with 0.25 and 0.375-inch ports and composition seats, refer to figure 13.** Place the disk (key 29) on the valve plug tip (key 30). Place the disk retainer (key 28) over the disk, and then thread the disk retainer onto the valve plug guide (key 27).

CAUTION

To avoid failure in service of valves with 0.5 through 1-inch ports and composition seats, never reuse an old valve plug guide with a new valve plug tip. Using an old valve plug guide with a new plug tip requires drilling a new pin hole in the valve plug guide, which will weaken the guide. However, a used valve plug tip may be reused with a new valve plug guide.

For valves with 0.5 through 1-inch ports and composition seats, refer to figure 13. Insert the disk (key 29) in the valve plug guide (key 27). Screw the tip (key 30) onto the valve plug guide to clamp the disk in place. Using a 3/32-inch bit, drill through the valve plug guide using the hole in the tip as a drilling guide. Remove any chips or burrs and drive in a new pin (key 31).

CAUTION

To avoid failure in service of valves with 1.5 and 2-inch ports and composition seats, never reuse an old valve plug tip with a new valve plug guide. Using an old valve plug tip with a new valve plug guide requires drilling a new pin hole in the valve plug tip, which will weaken the tip. However, a used valve plug guide may be reused with a new valve plug tip.

For valves with 1.5 and 2-inch ports and composition seats, refer to figure 13. Insert the disk (key 29) in the valve plug guide (key 27). Screw the tip (key 30) into the valve plug guide to clamp the disk in place. Using a 3/32-inch bit, drill through the valve plug tip using the hole in the valve plug guide as a drilling guide. Remove any chips or burrs and drive in a new pin (key 31).

For valves with 3 and 4-inch ports and composition seats, refer to figure 13. Insert the disk (key 29) in the valve plug guide (key 27). Place the tip (key 30) against the valve plug guide to clamp the disk in place. Insert the cap screw (key 32) through the tip and thread it into valve plug guide to secure the tip to the valve plug guide.

CAUTION

To avoid weakening the adaptor that may cause failure in service, never reuse an old adaptor with a new valve plug or valve plug guide. Using an old adaptor with a new valve plug or valve plug guide requires drilling a new pin hole in the adaptor, which will weaken the adaptor. However, a used valve plug or valve plug guide may be reused with a new adaptor.

2. Thread the valve plug (key 2) or, the valve plug guide (key 27, figure 13) if the valve has composition seats, onto the adaptor (key 24, figure 11). Tighten to the torque value given in figure 10.

Note

Valve plugs may not be pre-drilled. Follow the procedure in the following step.

3. If the valve plug is not pre-drilled, drill a hole according to figure 10. Otherwise, select the proper drill size (figure 10) and drill through the adaptor using the hole in the valve plug as a guide. Remove any chips or burrs and drive in a new pin (key 8) to lock the assembly.

Note

With some valve plug sizes and configurations, the valve plug or tip will slide through the seat ring retainer and bushing assembly, and in other configurations it won't.

4. If the valve plug (key 2) or valve plug tip (key 30, figure 13) will not slide through the seat ring retainer

and bushing assembly (keys 3 and 26), proceed as follows:

- a. Slide the seat ring retainer and bushing assembly (keys 3 and 26) over the adaptor (key 24, figure 11) so that the bushing rests on the shoulder of the valve plug or valve plug guide.
 - b. Place the spiral wound gasket, shim, and bonnet gasket (keys 12, 25, and 10) on the shoulder of the seat ring retainer.
 - c. Place a wrench on the flat areas of the stem just below the threads for the actuator/stem connection to keep the stem from turning.
 - d. Screw the adaptor (key 24, figure 11), which also includes the valve plug or valve plug guide and seat ring retainer and bushing assembly and gaskets, onto the stem/bellows assembly (key 20, figure 11). Tighten the adaptor until it is snug. Then, turn the adaptor until the valve stem hole lines up with the next adaptor pin hole. Drive in a new pin (key 36) to lock the assembly.
 - e. Install the seat ring gasket (key 13), and replace the seat ring (key 9).
 - f. Install the seat ring retainer and bushing assembly, which also contains the valve plug/adaptor assembly or valve plug guide/adaptor assembly, on the top of the seat ring, ensuring that the seat ring retainer slips onto the seat ring properly. Any rotation orientation of the seat ring retainer with respect to the valve body is acceptable.
 - g. Place a new gasket (key 22, figure 11) over the stem and bellows assembly.
5. If the valve plug (key 2) or the valve plug tip (key 30, figure 13) will slide through the seat ring retainer and bushing assembly (keys 3 and 26), proceed as follows:
- a. Place a wrench on the flat areas of the stem just below the threads for the actuator/stem connection to keep the stem from turning.
 - b. Screw the adaptor (key 24, figure 11), which also includes the valve plug or valve plug guide onto the stem/bellows assembly (key 20, figure 11). Tighten the adaptor until it is snug. Then, turn the adaptor until the valve stem hole lines up with the next adaptor pin hole. Drive in a new pin (key 36) to lock the assembly.

c. Install the seat ring gasket (key 13), and replace the seat ring (key 9).

d. Install the seat ring retainer and bushing assembly on the top of the seat ring, ensuring that the seat ring retainer slips onto the seat ring properly. Any rotation orientation of the seat ring retainer with respect to the valve body is acceptable.

e. Place the spiral wound gasket, shim, and bonnet gasket (keys 12, 25, and 10) on the shoulder of the seat ring retainer.

f. Slide the valve plug/adaptor assembly or the valve plug guide/adaptor assembly and the connected stem and bellows assembly into the seat ring retainer and bushing assembly (keys 3 and 26).

g. Place a new gasket (key 22, figure 11) over the stem and bellows assembly.

6. Mount the bonnet on the valve body and complete the assembly according to steps 10 through 15 of the Replacing Packing procedure, omitting steps 12 and 13 if new packing is not being installed, and being sure to observe the note prior to step 11.

ENVIRO-SEAL® Bellows Seal and Bonnet

Replacing a Plain or Extension Bonnet with an ENVIRO-SEAL Bellows Seal (Stem/Bellows Assembly) and Bonnet

Instructions are provided for replacing a plain or extension bonnet with an ENVIRO-SEAL bellows seal bonnet when the existing valve has a metal seat. If the valve has a composition seat, refer to figure 13 and to composition seat information in the Valves with ENVIRO-SEAL Bellows Seal Bonnet procedure of the Trim Maintenance section.

1. Remove the actuator and bonnet according to steps 1 through 6 of the Replacing Packing procedure of the Maintenance section.

Note

With some valve plug sizes and configurations, the valve plug will slide through the seat ring retainer and bushing assembly, and in other configurations it won't. If the valve

plug will not slide through the seat ring retainer and bushing assembly, then the valve plug and stem assembly and the seat ring retainer and bushing assembly must be removed together.

- Using care, remove the valve plug and stem assembly, and, if necessary, the seat ring retainer and bushing assembly from the valve body.
- Remove and discard the existing bonnet gasket (key 10, figure 12). Cover the valve body opening to protect sealing surfaces and to prevent foreign material from entering the valve body cavity.

Note

The ENVIRO-SEAL stem/bellows assembly for easy-e valves is available only with a threaded and drilled plug/adaptor connection. The existing valve plug can be reused with the new stem/bellows assembly or a new plug can be installed.

- Inspect the existing valve plug. If the plug is in good condition, it can be reused with the new ENVIRO-SEAL stem/bellows assembly. To remove the existing valve plug from the stem, first, place the existing plug stem assembly in a soft-jaw chuck or other type of vise so that the jaws grip a portion of the valve plug that is not a seating surface. Drive out or drill out the pin (key 8, figure 12).
- Place a wrench on the flat areas on the existing valve stem just below the threads for the actuator/stem connection. Then, unscrew the stem from the valve plug (key 2, figure 12).

CAUTION

When installing a valve plug on the ENVIRO-SEAL stem/bellows assembly, the valve stem must not be rotated. Damage to the bellows may result.

Do not grip the bellows shroud or other parts of the stem/bellows assembly. Grip only the flat areas on the stem where it extends out of the top of the bellows shroud.

Note

The ENVIRO-SEAL stem/bellows assembly has a one-piece stem.

Table 4. Recommended Torque for ENVIRO-SEAL Bellows Seal Packing Flange Nuts

VALVE SIZE, INCHES	VALVE STEM DIAMETER THROUGH PACKING	MINIMUM TORQUE		MAXIMUM TORQUE	
		N•m	Lbf•in	N•m	Lbf•in
0.5 - 2	1/2	2	22	4	33
3 - 4	1	5	44	8	67

6. To attach the valve plug to the stem of the new ENVIRO-SEAL stem/bellows assembly, it is necessary to first attach the valve plug to the adaptor (key 24, figure 11). Locate the adaptor. Notice that a hole has not been drilled in the adaptor threads where the valve plug screws onto the adaptor.

Secure the valve plug in a soft-jaw chuck or other type of vise. Do not grip the plug on any seating surface. Position the plug in the chuck or vise for easy threading of the adaptor. Thread the adaptor into the valve plug and tighten to the torque value given in figure 10.

Note

Valve plugs may not be pre-drilled. Follow the procedure in the following step.

7. If the valve plug is not pre-drilled, drill a hole according to figure 10. Otherwise, select the proper size of drill bit (figure 10) and drill through the adaptor using the hole in the valve plug as a guide. Remove any metal chips or burrs and drive in a new pin (key 8, figure 12) to lock the valve plug/adaptor assembly together.

Note

For some valve plug configurations, you must place the valve plug/adaptor assembly inside the seat ring retainer and bushing assembly before attaching the adaptor to the stem extending from the bottom of the ENVIRO-SEAL stem/bellows assembly. If this task is necessary, then place the spiral wound gasket, shim, and bonnet gasket (keys 12, 25, and 10, figure 12) on the shoulder of the seat ring retainer. Check the existing seat ring retainer and bushing assembly for clearances. If necessary, use appropriate procedures to support the seat ring retainer while screwing the valve plug/adaptor assembly onto the

valve stem extending from the ENVIRO-SEAL stem/bellows assembly.

8. Place a wrench on the flat areas of the valve stem just below the threads for the actuator/stem connection to keep the stem from turning.
9. Screw the adaptor (key 24, figure 11), which also includes the valve plug or valve plug guide and may include the seat ring retainer and bushing assembly and gaskets, onto the valve stem. Tighten the adaptor until it is finger-tight. Then, tighten the adaptor with a wrench until the valve stem hole lines up with the next adaptor pin hole. Drive in a new pin (key 36, figure 11) to lock the assembly. Make certain the spiral wound gasket, shim, and bonnet gasket (keys 12, 25, and 10, figure 12) are located on the shoulder of the seat ring retainer.
10. Inspect the seat ring. Replace, if necessary.
11. Install the new stem/bellows assembly with valve plug/adaptor by placing it into the valve body.
12. Place a new gasket (key 22, figure 11) over the stem/bellows assembly. Place the new ENVIRO-SEAL bonnet over the stem/bellows assembly.
13. Properly lubricate the bonnet stud bolts. Install and tighten the bonnet hex nuts to the proper torque.
14. Install new packing and the metal packing box parts according to the appropriate arrangement in figure 14 or 15.
15. Install the packing flange. Properly lubricate the packing flange stud bolts and the faces of the packing flange nuts.

For graphite packing, tighten the packing flange nuts to the maximum recommended torque shown in table 4. Then, loosen the packing flange nuts, and retighten them to the recommended minimum torque shown in table 4.

For other packing types, tighten the packing flange nuts alternately in small equal increments until one of the nuts reaches the minimum recommended torque shown in table 4. Then, tighten the remaining flange nuts until the packing flange is level and at a 90-degree angle to the valve stem.

16. Install travel indicator parts, stem locknuts, and mount the actuator on the valve body according to the procedure in the appropriate actuator instruction manual.

Replacing an Installed ENVIRO-SEAL Bellows Seal (Stem/Bellows Assembly)

Instructions are provided for replacing an ENVIRO-SEAL bellows seal (stem/bellows assembly) when the existing valve has a metal seat. If the valve has a composition seat, refer to figure 13 and to composition seat information in the Valves with ENVIRO-SEAL Bellows Seal Bonnet procedure of the Trim Maintenance section.

1. Remove the actuator and bonnet according to steps 1 through 5 of the Replacing Packing procedure of the Maintenance section.

Note

With some valve plug sizes and configurations, the valve plug will slide through the seat ring retainer and bushing assembly, and in other configurations it won't. If the valve plug will not slide through the seat ring retainer and bushing assembly, then the valve plug and stem assembly and the seat ring retainer and bushing assembly must be removed together.

2. Using care, remove the valve plug and stem assembly, and, if necessary, the seat ring retainer and bushing assembly from the valve body. Remove and discard the existing bonnet gasket (key 10, figure 12) and gasket (key 22, figure 11). Cover the valve body opening to protect sealing surfaces and to prevent foreign material from entering the valve body cavity.

CAUTION

The ENVIRO-SEAL stem/bellows assembly for easy-e valves is available only with a threaded and pinned adaptor/stem connection. The existing valve plug can be reused with the new stem/bellows assembly or a new plug can be installed. If the existing valve plug is reused, and the adaptor is in good condition, it may be reused also. However, to avoid weakening the adaptor that may cause failure in service, never reuse an old adaptor with a new valve plug. Using an old adaptor with a new plug requires drilling a new pin hole in the adaptor, which will weaken the adaptor. However, a used valve plug may be reused with a new adaptor.

3. Inspect the existing valve plug and adaptor. If they are in good condition, they can be reused with the new stem/bellows assembly, and they do not need to be separated.

CAUTION

When removing/installing a valve plug on the ENVIRO-SEAL stem/bellows assembly, the valve stem must not be rotated. Damage to the bellows may result.

Do not grip the bellows shroud or other parts of the stem/bellows assembly. Grip only the flat areas on the stem where it extends out of the top of the bellows shroud.

Note

The ENVIRO-SEAL stem/bellows assembly has a one-piece stem.

4. If the existing valve plug and adaptor are not in good condition and must be replaced, first, place the existing stem/bellows assembly and valve plug and adaptor assembly in a soft-jaw chuck or other type of vise so that the jaws grip a portion of the valve plug that is not a seating surface. Drive out or drill out pin (key 8, figure 12). Drive out pin (key 36, figure 11).

5. Use a wrench on the flat areas on the valve stem just below the threads for the actuator/stem connection in a soft-jaw chuck or vice to keep the stem from turning. Then, unscrew the valve plug from the adaptor and the adaptor from the stem/bellows assembly.

6. To attach either the existing valve plug or a new one to the stem of the new ENVIRO-SEAL stem/bellows assembly, it is necessary to first attach the valve plug to the adaptor (key 24, figure 11), if the valve plug was removed from the adaptor. Locate the adaptor. Notice that a hole has not been drilled in the new adaptor threads where the valve plug screws onto the adaptor.

If installing either a new valve plug and/or a new adaptor, secure the valve plug in a soft-jaw chuck or other type of vise. Do not grip the plug on any seating surface. Position the plug in the chuck or vise for easy threading of the adaptor. Thread the adaptor into the valve plug and tighten to the torque values given in figure 10.

7. Complete the installation by following steps 7 through 16 of the Replacing a Plain or Extension Bonnet with an ENVIRO-SEAL Bellows Seal and Bonnet procedure provided in the previous section.

Purging the ENVIRO-SEAL Bellows Seal Bonnet

The ENVIRO-SEAL bellows seal bonnet has been designed so that it can be purged or leak tested. Refer to figure 11 for an illustration of an ENVIRO-SEAL bellows seal bonnet, and perform the following steps for purging or leak testing.

1. Remove the two diametrically opposed pipe plugs (key 16).

2. Connect a purging fluid to one of the pipe plug connections.

3. Install appropriate piping or tubing in the other pipe plug connection to pipe away the purging fluid or to make a connection to an analyzer for leak testing.

4. When purging or leak testing has been completed, remove the piping or tubing and reinstall the pipe plugs (key 16).

Parts Ordering

Each valve is assigned a serial number which can be found on the valve body. This same number also appears on the actuator nameplate when the valve is shipped from the factory as part of a control valve assembly. Refer to the serial number when contacting your Fisher sales office for technical assistance. When ordering replacement parts, refer to the serial number and to the 11-character part number for each part required from the following parts list.

Note

Use only genuine Fisher replacement parts. Components that are not supplied by Fisher should not, under any circumstances, be used in any Fisher valve, because they will void your warranty, might adversely affect the performance of the valve, and might jeopardize worker and workplace safety.

Parts Kits

Gasket parts kits are in key 10 table.

Packing Kits (non-live-loaded)

Stem Diameter, mm (Inches) Yoke Boss Diameter, mm (Inches)	9.5 (3/8) 54 (2-1/8)	12.7 (1/2) 71 (2-13/16)	19.1 (3/4) 90 (3-9/16)
PTFE (Contains keys 6, 8, 10, 11, and 12)	RPACKX00012	RPACKX00022	RPACKX00032
Double PTFE (Contains keys 6, 8, 11, and 12)	RPACKX00042 ⁽¹⁾⁽²⁾	RPACKX00052 ⁽¹⁾	RPACKX00062 ⁽¹⁾
PTFE/Composition (Contains keys 7, 8, 11, and 12)	RPACKX00072	RPACKX00082	RPACKX00092
Single Graphite Ribbon/Filament (Contains keys 7 [ribbon ring], 7 [filament ring], 8, and 11)	RPACKX00102	RPACKX00112	RPACKX00122
Double Graphite Ribbon/Filament (Contains keys 7 [ribbon ring], 7 [filament ring], 8, and 11)	RPACKX00162	RPACKX00172	RPACKX00182
1. These parts kits contain one extra lower wiper (key 30). Discard this extra part upon assembly. 2. This parts kit contains one extra packing ring (key 7). Discard this extra part upon assembly.			

Packing Kits (ENVIRO-SEAL) Repair

Stem Diameter, mm (Inches) Yoke Boss Diameter, mm (Inches)	9.5 (3/8) 54 (2-1/8)	12.7 (1/2) 71 (2-13/16)	19.1 (3/4) 90 (3-9/16)
Double PTFE (Contains keys 214, 215, and 218)	RPACKX00192	RPACKX00202	RPACKX00212
Graphite ULF (Contains keys 207, 208, 209, 210, and 214)	RPACKX00592	RPACKX00602	RPACKX00612
Duplex (Contains keys 207, 209, 214, and 215)	RPACKX00292	RPACKX00302	RPACKX00312

Packing Kits (ENVIRO-SEAL) Retrofit

Stem Diameter, mm (Inches) Yoke Boss Diameter, mm (Inches)	9.5 (3/8) 54 (2-1/8)	12.7 (1/2) 71 (2-13/16)	19.1 (3/4) 90 (3-9/16)
Double PTFE (Contains keys 200, 201, 211, 212, 214, 215, 216, 217, and 218)	RPACKXRT012	RPACKXRT022	RPACKXRT032
Graphite ULF (Contains keys 200, 201, 207, 208, 209, 210, 211, 212, 214, and 217)	RPACKXRT262	RPACKXRT272	RPACKXRT282
Duplex (Contains keys 200, 201, 207, 209, 211, 212, 214, 215, 216, and 217)	RPACKXRT212	RPACKXRT222	RPACKXRT232

Note

Neither Emerson, Emerson Process Management, nor Fisher assume responsibility for the selection, use, or maintenance of any product. Responsibility for proper selection, use, and maintenance of any Fisher product remains solely with the purchaser and end-user.

Parts List Bonnet

Note

Part numbers are shown for recommended spares only. For part numbers not shown, contact your Fisher sales office.

Key	Description	Part Number	Key	Description	Part Number
			7*	ENVIRO-SEAL Bellows Seal Packing Ring for low chloride graphite ribbon/filament packing arrangement	
				Ribbon packing ring for 9.5 mm (3/8 inch) and size 2 with 12.7 mm (1/2 inch) stem (4 req'd)	18A0908X012
				Filament packing ring for 9.5 mm (3/8 inch) and size 2 with 12.7 mm (1/2 inch) stem (4 req'd)	1P3905X0172
				Ribbon packing ring for size 3 and 4 with 12.7 mm (1/2 inch) stem (4 req'd)	18A0918X012
				Filament packing ring for size 3 and 4 with 12.7 mm (1/2 inch) stem (4 req'd)	14A0915X042
2	Baffle, (for extension bonnets only)		8	Spring, S31600 (for single PTFE packing only)	
3	Packing Flange, S31600 (316 SST)		8	Spacer, N04400 (Monel) (for single PTFE packing only)	
3	ENVIRO-SEAL Bellows Seal Packing Flange		8	Lantern Ring (for double PTFE packing)	
4	Packing Flange Stud, S31600 (2 req'd)		8	ENVIRO-SEAL Bellows Seal Spring	
4	ENVIRO-SEAL Bellows Seal Stud Bolt		8	ENVIRO-SEAL Bellows Seal Spacer	
5	Packing Flange Nut, S31600 (2 req'd)		10	Special Washer, S31600 (for single PTFE packing)	
5	ENVIRO-SEAL Bellows Seal Hex Nut		11*	Packing Box Ring	
6*	Packing Set, PTFE (2 req'd for double packing)			Single PTFE packing	
	9.5 mm (3/8-inch) stem	1R290001012		9.5 mm (3/8-inch) stem	
	12.7 mm (1/2-inch) stem	1R290201012		S31600 (std for S31600 and S41600 trims)	1J873135072
	19.1 mm (3/4-inch) stem	1R290401012		N05500 (std for N05500 trim)	1J873146222
6*	ENVIRO-SEAL Bellows Seal Packing Set			12.7 mm (1/2-inch) stem	
	PTFE for 9.5 mm (3/8-inch) stem (1 req'd for single packing, 2 req'd for double packing)	12A9016X012		S31600 (std for S31600 and S41600 trims)	1J873235072
	PTFE for size 2 with 12.7 mm (1/2 inch) stem (2 req'd for double packing)	12A9016X012		N05500 (std for N05500 trim)	1J873246222
	PTFE for size 3 and 4 with 12.7 mm (1/2 inch) stem (2 req'd for double packing)	12A8832X012		19.1 mm (3/4-inch) stem	
				S31600 (std for S31600 and S41600 trims)	1J873335072
				N05500 (std for N05500 trim)	1J873346222
6*	Packing Set, PTFE/KALREZ			Double PTFE packing	
	9.5 mm (3/8-inch) stem	13B0963X012		9.5 mm (3/8-inch) stem	
	12.7 mm (1/2-inch) stem	13B0964X012		S31600 (std for S31600 and S41600 trims)	1J873135072
	19.1 mm (3/4-inch) stem	13B0965X012		Glass-filled PTFE (std for N05500 trim)	17A6872X012
				12.7 mm (1/2-inch) stem	
7*	Packing Ring, PTFE/comp (for double packing)			S31600 (std for S31600 and S41600 trims)	1J873235072
	9.5 mm (3/8-inch) stem			Glass-filled PTFE (std for N05500 trim)	17A6873X012
	PTFE/comp (7 req'd)	1F3370X0012		Double PTFE packing (cont'd)	
	12.7 mm (1/2-inch) stem			19.1 mm (3/4-inch) stem	
	PTFE/comp (10 req'd)	1E319001042		S31600 (std for S31600 and S41600 trims)	1J873335072
	19.1 mm (3/4-inch) stem			Glass-filled PTFE (std for N05500 trim)	17A6874X012
	PTFE/comp (8 req'd)	1E319101042		PTFE/composition packing	
7*	Packing Ring, graphite ribbon ring (2 req'd for single packing, 3 req'd for double packing)			9.5 mm (3/8-inch) stem	
	9.5 mm (3/8-inch) stem	1V3160X0022		S31600 (std for S31600 and S41600 trims)	1J873135072
	12.7 mm (1/2-inch) stem	1V3802X0022		Glass-filled PTFE (std for N05500 trim)	17A6872X012
	19.1 mm (3/4-inch) stem	1V2396X0022		12.7 mm (1/2-inch) stem	
				S31600 (std for S31600 and S41600 trims)	1J873235072
				N05500 (std for N05500 trim)	1J873246222
				19.1 mm (3/4-inch) stem	
				S31600 (std for S31600 and S41600 trims)	1J873335072
				Glass-filled PTFE (std for N05500 trim)	17A6874X012
7*	Packing Ring, graphite filament ring		12*	Upper Wiper, felt	
	9.5 mm (3/8-inch) stem (2 req'd for single packing, 4 req'd for double packing)	1F3370X0322		9.5 mm (3/8-inch) stem	1J872606332
	12.7 mm (1/2-inch) stem (3 req'd for single packing, 5 req'd for double packing)	1E3190X0222		12.7 mm (1/2-inch) stem	1J872706332
	19.1 mm (3/4-inch) stem (2 req'd for single packing, 4 req'd for double packing)	1E3191X0282		19.1 mm (3/4-inch) stem	1J872806332
				ENVIRO-SEAL Bellows Seal Upper Wiper	
				For 9.5 mm (3/8 inch) and size 2 with 12.7 mm (1/2 inch) stem	18A0868X012
				For size 3 & 4 with 12.7 mm (1/2 inch) stem	18A0870X012
			13	Packing Follower	

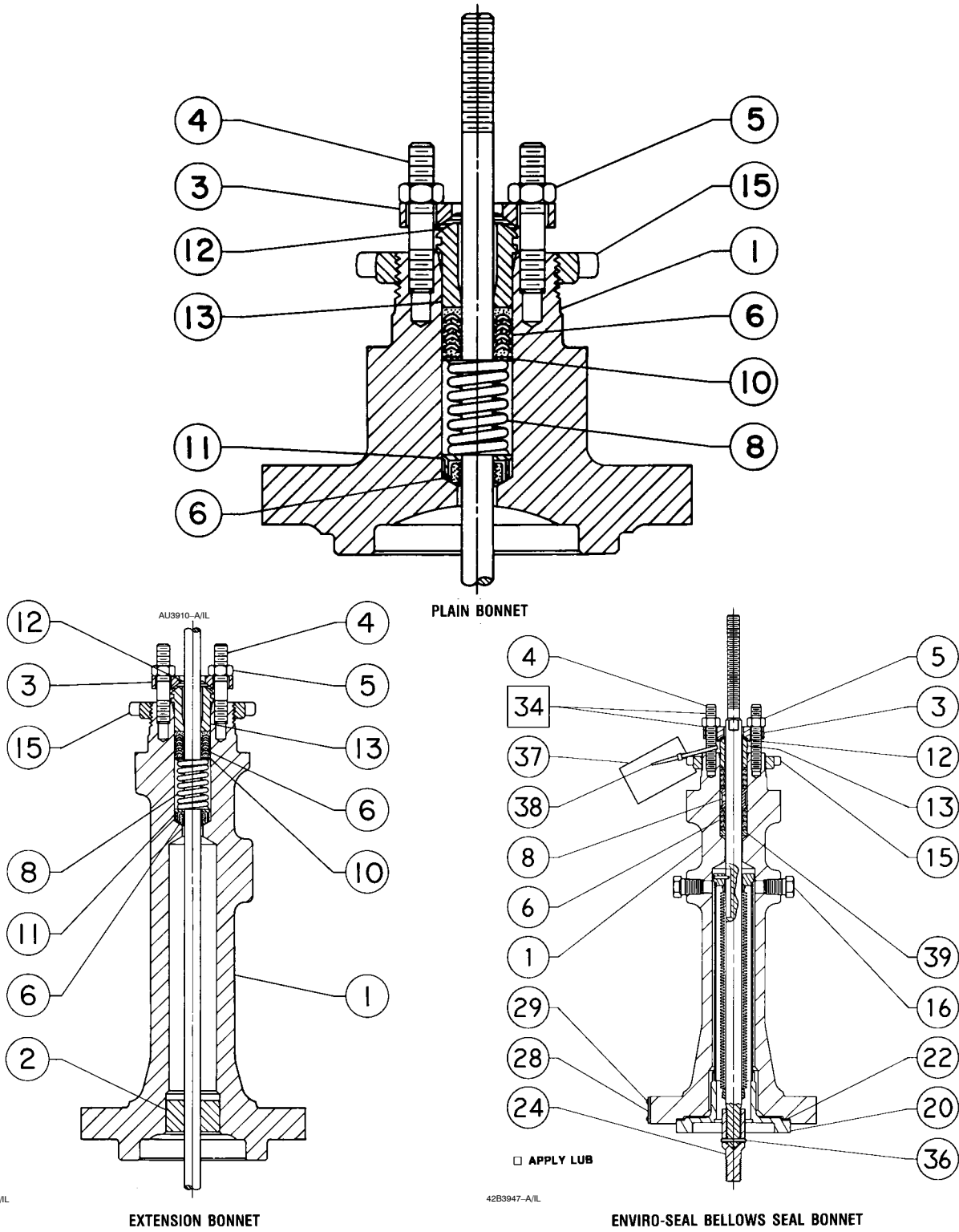

CU3911-D/IL

42B3947-A/IL

Figure 11. Typical Bonnets

Key	Description	Part Number	Key	Description	Part Number
13*	ENVIRO-SEAL Bellows Seal Bushing For 9.5 mm (3/8 inch) stem (1 req'd), for size 2 with 12.7 mm (1/2 inch) stem, (2 req'd) S31600/PTFE R30006 S31600/Cr Ct	18A0820X012 18A0819X012 11B1155X012	24	ENVIRO-SEAL Bellows Seal Adaptor	
	For size 3 and 4 with 12.7 mm (1/2 inch) stem (1 req'd) S31600/PTFE R30006 S31600/Cr Ct	18A0824X012 18A0823X012 11B1157X012	27	Pipe Nipple, for lub/isolating valve, steel	
13*	ENVIRO-SEAL Bellows Seal Bushing/Liner For 9.5 mm (3/8 inch) stem (1 req'd), for size 2 with 12.7 mm (1/2 inch) stem (2 req'd) N10276 bushing, PTFE/glass liner N10276 bushing, PTFE/carbon liner	12B2713X012 12B2713X042	28	ENVIRO-SEAL Bellows Seal Nameplate, Warning	
	For size 3 and 4 with 12.7 mm (1/2 inch) stem (1 req'd) N10276 bushing, PTFE/glass liner N10276 bushing, PTFE/carbon liner	12B2715X012 12B2715X042	29	ENVIRO-SEAL Bellows Seal Drive Screw (2 req'd)	
14	Pipe Plug (not shown)		34	Lubricant, Never-Seez Nickel Special or equivalent (not furnished with valve)	
14	Lubricator		36*	ENVIRO-SEAL Bellows Seal Pin	12B3951X012
14	Lubricator/Isolating Valve		37	ENVIRO-SEAL Bellows Seal Warning Tag	
15	Yoke Locknut		38	ENVIRO-SEAL Bellows Seal Tie	
15	ENVIRO-SEAL Bellows Seal Yoke Locknut		39	ENVIRO-SEAL Bellows Seal Thrust Ring	
16	Pipe Plug (not shown)		200	Stud (2 req'd)	
16	ENVIRO-SEAL Bellows Seal Pipe Plug (2 req'd)		201	Packing Flange	
20*	ENVIRO-SEAL Bellows Seal Stem/Bellows Assembly 1 Ply Bellows S31603 trim mat'l, N06625 bellows mat'l Size 1 w/ 9.5 mm (3/8 inch) stem Size 1.5 w/ 9.5 mm (0.375 inch) stem Size 2 w/ 12.7 mm (1/2 inch) stem Size 3 w/ 12.7 mm (1/2 inch) stem Size 4 w/ 12.7 mm (1/2 inch) stem N06022 trim mat'l, N06022 bellows mat'l Size 1 w/ 9.5 mm (3/8 inch) stem Size 1.5 w/ 9.5 mm (3/8 inch) stem Size 2 w/ 12.7 mm (1/2 inch) stem Size 3 w/ 12.7 mm (1/2 inch) stem Size 4 w/ 12.7 mm (1/2 inch) stem 2 Ply Bellows S31603 trim mat'l, N06625 bellows mat'l Size 1 w/ 9.5 mm (3/8 inch) stem Size 1.5 w/ 9.5 mm (3/8 inch) stem Size 2 w/ 12.7 mm (1/2 inch) stem Size 3 w/ 12.7 mm (1/2 inch) stem Size 4 w/ 12.7 mm (1/2 inch) stem N06022 trim mat'l, N06022 bellows mat'l Size 1 w/ 9.5 mm (3/8 inch) stem Size 1.5 w/ 9.5 mm (3/8 inch) stem Size 2 w/ 12.7 mm (1/2 inch) stem Size 3 w/ 12.7 mm (1/2 inch) stem Size 4 w/ 12.7 mm (1/2 inch) stem	32B4224X012 32B4225X012 32B4226X012 32B4227X012 32B4228X012 32B4224X022 32B4225X022 32B4226X022 32B4227X022 32B4228X022 32B4224X032 32B4225X032 32B4226X032 32B4227X032 32B4228X032 32B4224X042 32B4225X042 32B4226X042 32B4227X042 32B4228X042	202	Spring, (2 req'd)	
			203	Spring guide packing follower	
			204	Screw, 18-8 SST (4 req'd)	
			205	Load Scale, 18-8 SST (2 req'd)	
			206	Indicator Disk, 18-8 SST	
			207*	Guide Bushing, white (2 req'd) For ENVIRO-SEAL and HIGH-SEAL packing Carbon-graphite for graphite packing 9.5 mm (3/8-inch) stem 12.7 mm (1/2-inch) stem 19.1 mm (3/4-inch) stem	12B5780X012 12B5782X012 12B5784X012
			208*	Guide Bushing, no color For ENVIRO-SEAL and HIGH-SEAL packing Carbon-Graphite for graphite packing 9.5 mm (3/8-inch) stem 12.7 mm (1/2-inch) stem 19.1 mm (3/4-inch) stem	12B5781X012 12B5783X012 12B5785X012
			209*	Packing Ring ⁽¹⁾ (3 req'd) For ENVIRO-SEAL and HIGH-SEAL packing Graphite Composite for graphite packing 9.5 mm (3/8-inch) stem 12.7 mm (1/2-inch) stem 19.1 mm (3/4-inch) stem	12B5798X012 12B5799X012 12B5800X012
			210*	Packing Ring (2 req'd) For ENVIRO-SEAL and HIGH-SEAL packing Graphite Ribbon for graphite packing 9.5 mm (3/8-inch) stem 12.7 mm (1/2-inch) stem 19.1 mm (3/4-inch) stem	1V3160X0022 1V3802X0022 1V2396X0022
			211*	Packing Box Ring For ENVIRO-SEAL packing S31600 For PTFE Packing 9.5 mm (3/8-inch) stem 12.7 mm (1/2-inch) stem 19.1 mm (3/4-inch) stem For ENVIRO-SEAL and HIGH-SEAL packing S31600 For Graphite packing and Duplex packing 9.5 mm (3/8-inch) stem 12.7 mm (1/2-inch) stem 19.1 mm (3/4-inch) stem	1J873135072 1J873235072 1J873335072 12B5774X012 12B5775X012 12B5776X012
22*	ENVIRO-SEAL Bellows Seal Bonnet Gasket (graphite/S31600) Size 0.5 through 1.25 Size 1.5 Size 2 Size 3 Size 4	12B6316X022 12B6317X022 12B6318X022 12B6319X022 12B6320X022	212	Hex Nut (2 req'd)	

*Recommended spare parts
1. Part number is stamped on part.

Instruction Manual

Form 5118
April 2005

EZ Valve

Key	Description	Part Number	Key	Description	Part Number
213	Lubricant, Never-Seez Nickel Special or equivalent		7*	Stem	See following table
214*	Anti-Extrusion washer (4 req'd) For ENVIRO-SEAL packing PTFE filled (off-white) For PTFE packing		8*	Pin	See following table
	9.5 mm (3/8-inch) stem	12B6336X022	9*	Seat Ring	See following table
	12.7 mm (1/2-inch) stem	12B6335X022	10*	Bonnet Gasket	See following table
	19.1 mm (3/4-inch) stem	12B6660X012	12*	Spiral Wound Gasket	See following table
214*	Packing Washer (5 req'd) For ENVIRO-SEAL packing PTFE		13*	Seat Ring Gasket	See following table
	For Graphite packing and Duplex packing		15	Cap Screw or Stud Bolt	
	9.5 mm (3/8-inch) stem	12B6936X012	16	Nut	
	12.7 mm (1/2-inch) stem	12B6937X012	17	Pipe Plug, for use in valve bodies with drain tapping only	
	19.1 mm (3/4-inch) stem	12B6938X012	18	Flow Arrow, SST	
215*	Packing Set (2 req'd) For ENVIRO-SEAL packing PTFE-carbon/PTFE		19	Drive Screw, SST (4 req'd)	
	9.5 mm (3/8-inch) stem	12B6663X012	25*	Shim	See following table
	12.7 mm (1/2-inch) stem	12B6667X012	26*	Bushing	See following table
	19.1 mm (3/4-inch) stem	12B6671X012		(See additional table for part numbers of assemblies that include both the seat ring retainer and the bushing)	
216	Lantern Ring		27*	Valve Plug Guide (for composition seats only)	See following table
217	Spring Pack Assembly		28*	Disk Retainer, (composition seats only)	
218*	Lower wiper For ENVIRO-SEAL packing PTFE			6.4 mm (0.25-inch) port diameter	
	For PTFE packing			S31600	16A3441X012
	9.5 mm (3/8-inch) stem	1J872106992		N05500	16A3441X042
	12.7 mm (1/2-inch) stem	1J872206992		S41600	16A3441X052
	19.1 mm (3/4-inch) stem	1J872306992		9.5 mm (0.375-inch) port diameter	
				S31600	16A5706X012
				N05500	16A5706X042
				S41600	16A5706X052
			29*	Disk, PTFE (composition seats only)	
				6.4 mm (0.25-inch) port diameter	13A1226X062
				9.5 mm (0.375-inch) port diameter	13A5125X042
				12.7 mm (0.5-inch) port diameter	1P696806242
				19.1 mm (0.75-inch) port diameter	1P696106242
				25.4 mm (1-inch) port diameter	1P696906242
				38.1 mm (1.5 inch) port diameter	1U279606242
				50.8 mm (2-inch) port diameter	1U279906242
				76.2 mm (3-inch) port diameter	1F5653X0012
				101.6 mm (4-inch) port diameter	16A3462X012
			30*	Tip (composition seats only)	See following table
			31*	Pin (composition seats only)	
				12.7 mm (0.5-inch) port diameter	
				S31600 and S41600	1B599038992
				N05500	1B5990X0032
				19.1 mm (0.75-inch) port diameter	
				S31600 and S41600	1P730438992
				N05500	1P7304X0032
				25.4 mm (1-inch) and 38.1 mm (1.5 inch) port diameter	
				S31600 and S41600	1B599335072
				N05500	1B5993X00B2
				50.8 mm (2-inch) port diameter	
				S31600 and S41600	1B599538992
				N05500	1B599540032
			32	Cap Screw (composition seat only)	
			33	Nameplate, stainless steel	
			34	Wire, lead	

Valve Body

1	Valve Body	
	If you need a valve body as a replacement part, order by valve size, serial number, and desired material.	
2*	Valve Plug	See following table
3*	Seat Ring Retainer (part numbers for the seat ring retainer/bushing assy are provided in a following table)	
	0.5, 0.75, & 1-inch valve	
	CB7Cu-1 (17-4PH SST)	25A6683X012
	CF8M (316 SST)	25A6683X022
	M35-1 (Monel)	25A6683X052
	1.5 inch valve	
	CB7Cu-1	25A6685X012
	1.5 inch valve	
	CF8M	25A6685X022
	M35-1	25A6685X052
	2-inch valve	
	CB7Cu-1	25A6687X012
	CF8M	25A6687X022
	M35-1	25A6687X052
	3-inch valve	
	CB7Cu-1	25A6689X012
	CF8M	25A6689X022
	M35-1	25A6689X052
	4-inch valve	
	CB7Cu-1	35A6691X012
	CF8M	35A6691X022
	M35-1	35A6691X052

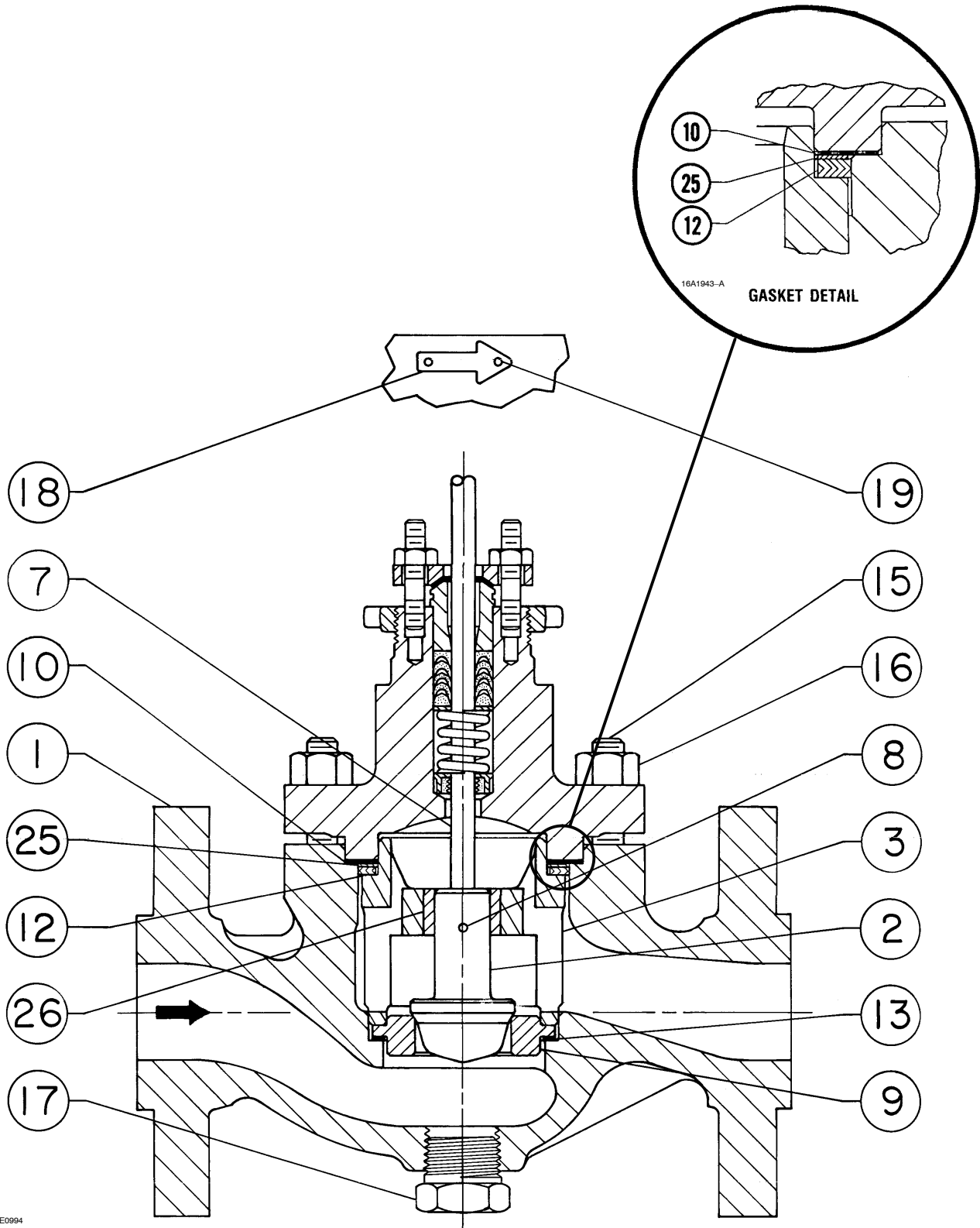
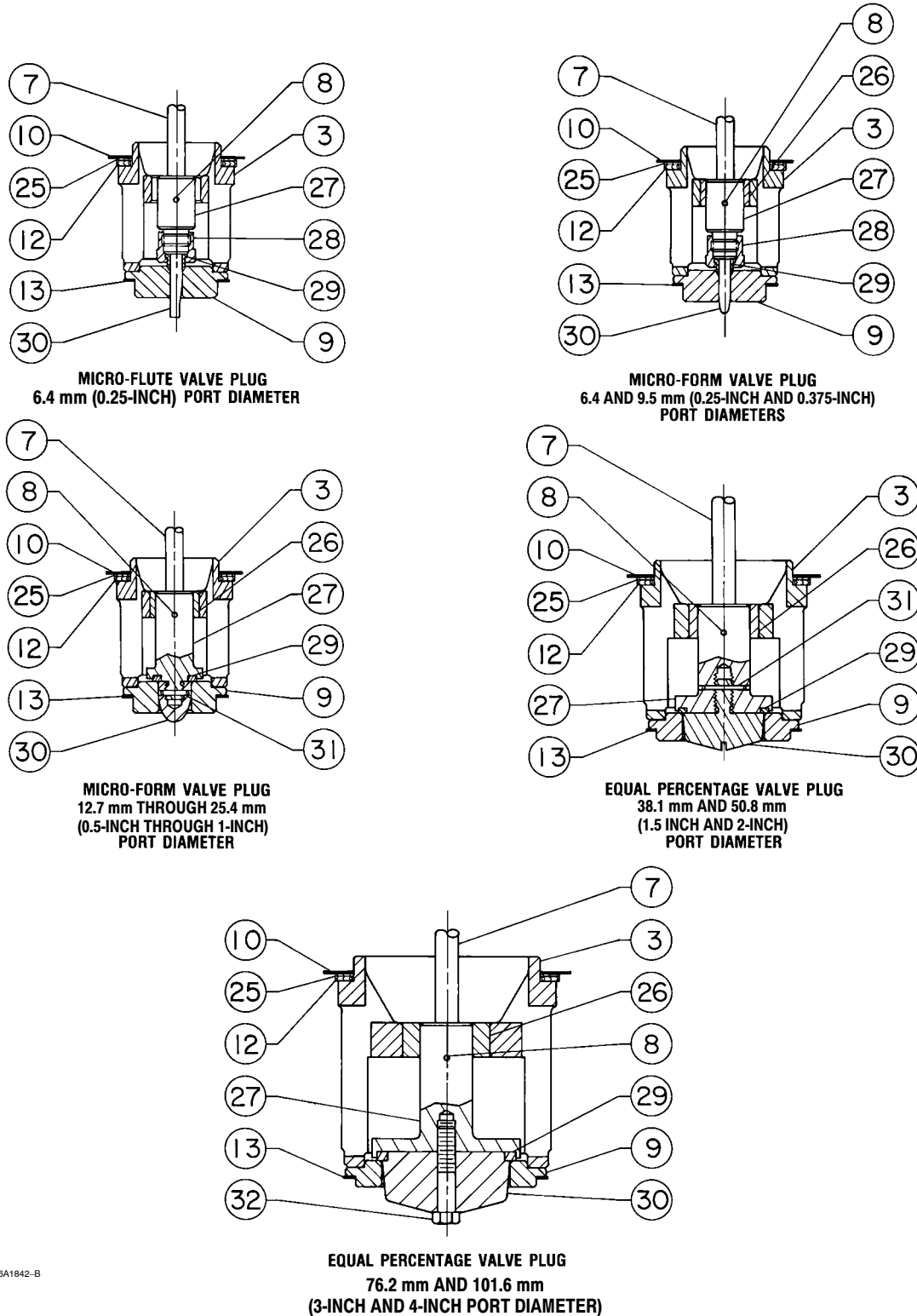

Figure 12. Design EZ Valve

E0994



46A1842-B

Figure 13. Composition Seats for Design EZ Valve

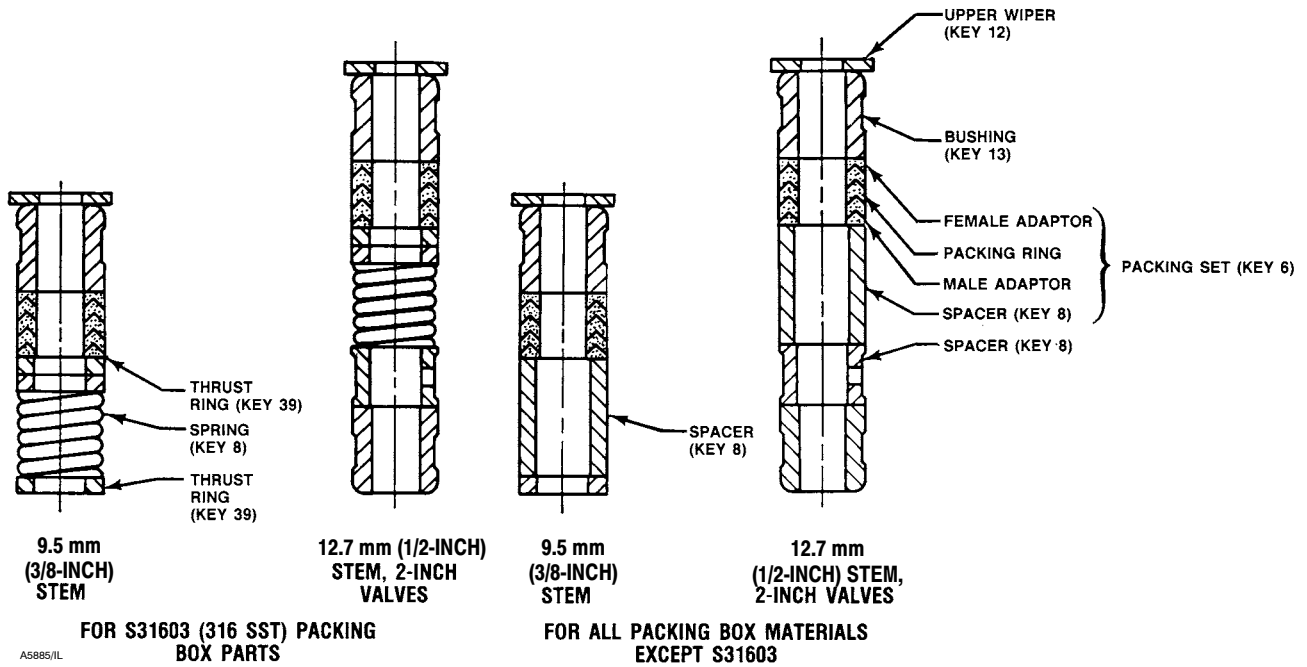

SINGLE ARRANGEMENTS

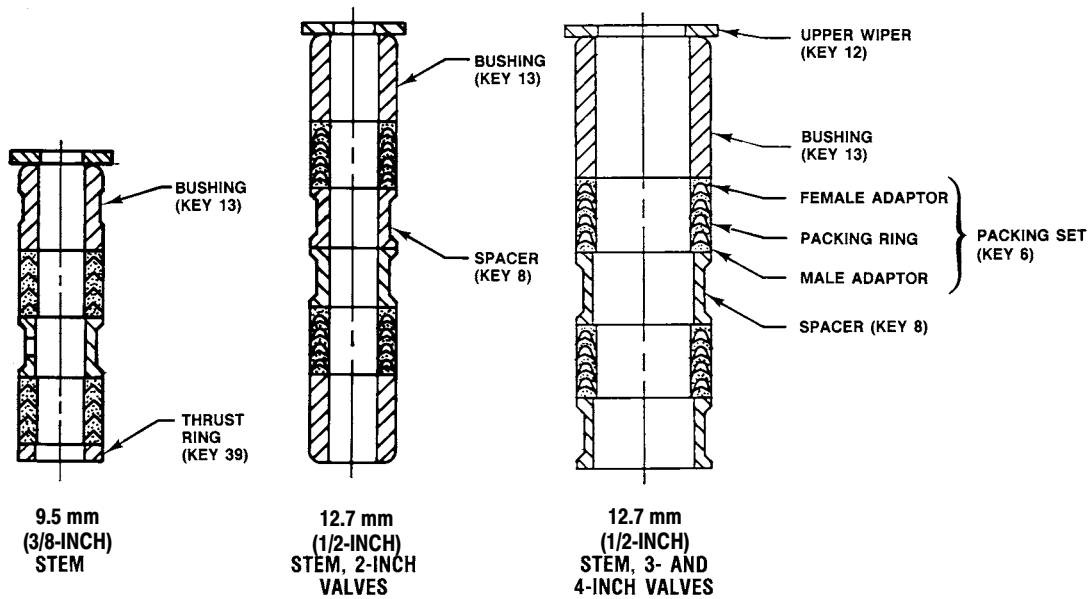

DOUBLE ARRANGEMENTS

Figure 14. PTFE Packing Arrangements for ENVIRO-SEAL Bellows Seal Bonnets

Instruction Manual

Form 5118
April 2005

EZ Valve

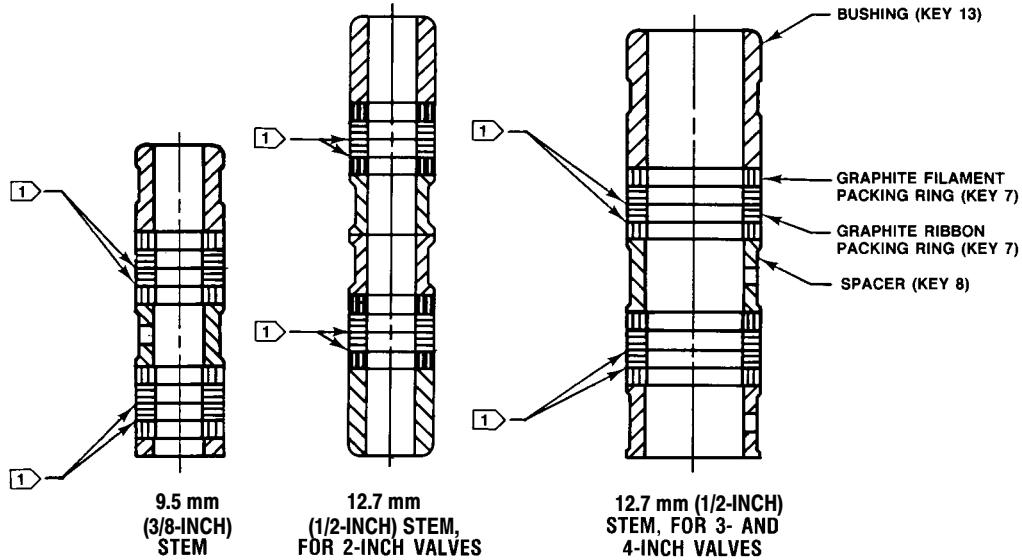

NOTE:
 1 0.102 mm (0.004 INCH) THICK SACRIFICIAL ZINC WASHERS;
 USE ONLY ONE BELOW EACH GRAPHITE RIBBON RING.

A5887-1/IL

Figure 15. Double Graphite Ribbon/Filament Arrangements for ENVIRO-SEAL Bellows Seal Bonnets

Key 2* Micro-Flow and Micro-Flute Valve Plug

VALVE SIZE, INCH	VALVE PLUG	PORT DIAMETER		VALVE STEM CONNECTION		VALVE PLUG MATERIAL		
		mm	Inch	mm	Inch	S31600 (316 SST) w/R30006 (Alloy 6) Seat & Tip	N05500 (K-Monel)	S41600 (416 SST)
0.5, 0.75, 1, 1.5, 2	Micro-Flow	4.8	0.1875			2V926950332	1V108146222	1V108146172
	Micro-Flute (1 flute)	6.4	0.25	9.5	3/8	2U868246422	1U844546222	1U844546172
	Micro-Flute (3 flutes)	6.4	0.25			2U868446422	1U844746222	1U844746172

Key 2* Equal Percentage (Including Micro-Form), Linear, and Quick-Opening Valve Plugs

VALVE SIZE, INCH	VALVE PLUG	PORT DIAMETER		VSC ⁽¹⁾		PLUG MATERIAL				
		mm	Inch	mm	Inch	S31600 (316 SST)	S31600 w/ CoCr-A (Alloy 6) Seat	S31600 w/ CoCr-A Seat & Guide	N05500 ⁽²⁾ (K-Monel)	S41600 (416 SST)
0.5, 0.75, 1, 1.5 & 2	Micro-Form	6.4	0.25	9.5	3/8	15A6500X012	15A6663X012	15A6664X012	15A6500X042	15A6500X052
		9.5	0.375			16A5708X012	16A5713X012	16A5711X012	16A5708X042	16A5708X052
		12.7	0.5			15A6502X012	15A6659X012	15A6660X012	15A6502X042	15A6502X052
		19.1	0.75			16A3335X012	16A3337X012	16A3339X012	16A3335X042	16A3335X052
		6.4	0.25	12.7	1/2	15A6501X012	---	---	15A6501X042	15A6501X052
		9.5	0.375			16A5709X012	16A5714X012	16A5712X012	16A5709X042	16A5709X052
	12.7	0.5	15A6503X012			15A6661X012	15A6662X012	15A6503X042	15A6503X052	
	19.1	0.75	16A3336X012	16A3338X012	16A3340X012	16A3336X042	16A3336X052			
	Quick Opening	25.4	1	9.5	3/8	15A6490X012	15A6516X012	15A6517X012	15A6490X042	15A6490X052
	Linear	25.4	1	12.7	1/2	15A6470X012	15A6614X012	15A6615X012	15A6470X042	15A6470X052
	Equal Percentage	25.4	1	12.7	1/2	15A6471X012	15A6616X012	15A6617X012	15A6471X042	15A6471X052
	1.5	Quick Opening	38.1	1.5	9.5	3/8	15A6492X012	15A6520X012	15A6521X012	15A6492X042
Linear		38.1	1.5	12.7	1/2	15A6493X012	15A6522X012	15A6523X012	15A6493X042	15A6493X052
Equal Percentage		38.1	1.5	9.5	3/8	15A6472X012	15A6618X012	15A6619X012	15A6472X042	15A6472X052
				12.7	1/2	15A6473X012	15A6620X012	15A6621X012	15A6473X042	15A6473X052
				9.5	3/8	15A6482X012	15A6638X012	15A6639X012	15A6482X042	15A6482X052
				12.7	1/2	15A6483X012	15A6640X012	15A6641X012	15A6483X042	15A6483X052
2, 3, 4	Quick Opening	50.8	2	12.7	1/2	15A6494X012	15A6524X012	15A6525X012	15A6494X042	15A6494X052
	Linear	50.8	2	19.1	3/4	15A6495X012	15A6526X012	15A6527X012	15A6495X042	15A6495X052
				12.7	1/2	15A6474X012	15A6622X012	15A6623X012	15A6474X042	15A6474X052
	Equal Percentage	50.8	2	19.1	3/4	15A6475X012	15A6624X012	15A6625X012	15A6475X042	15A6475X052
				12.7	1/2	15A6484X012	15A6642X012	15A6643X012	15A6484X042	15A6484X052
	19.1	3/4	15A6485X012	15A6644X012	15A6645X012	15A6485X042	15A6485X052			
3	Quick Opening	76.2	3	12.7	1/2	15A6496X012	15A6528X012	15A6529X012	15A6496X042	15A6496X052
	Linear	76.2	3	19.1	3/4	15A6497X012	15A6530X012	15A6531X012	15A6497X042	15A6497X052
				12.7	1/2	15A6476X012	15A6626X012	15A6627X012	15A6476X042	15A6476X052
	Equal Percentage	76.2	3	19.1	3/4	15A6477X012	15A6628X012	15A6629X012	15A6477X042	15A6477X052
				12.7	1/2	15A6486X012	15A6646X012	15A6647X012	15A6486X042	15A6486X052
	19.1	3/4	15A6487X012	15A6648X012	15A6649X012	15A6487X042	15A6487X052			
4	Quick Opening	101.6	4	12.7	1/2	15A6498X012	15A6532X012	15A6533X012	15A6498X042	15A6498X052
	Linear	101.6	4	19.1	3/4	15A6499X012	15A6534X012	15A6535X012	15A6499X042	15A6499X052
				12.7	1/2	15A6478X012	15A6630X012	15A6631X012	15A6478X042	15A6478X052
	Equal Percentage	101.6	4	19.1	3/4	15A6479X012	15A6632X012	15A6633X012	15A6479X042	15A6479X052
				12.7	1/2	15A6488X012	15A6650X012	15A6651X012	15A6488X042	15A6488X052
	19.1	3/4	15A6489X012	15A6652X012	15A6653X012	15A6489X042	15A6489X052			

1. Valve stem connection.

2. Monel materials in hydrofluoric acid service require special options. Contact your Fisher sales office for assistance.

Instruction Manual

Form 5118
April 2005

EZ Valve

Key 2*, 7*, and 8* Valve Plug/Stem Assembly for Plain Bonnet

VALVE SIZE, INCH	VALVE PLUG	PORT DIA		VSC(1)		PLUG MATERIAL					
		mm	Inch	mm	Inch	S31600 (316 SST)	S31600 w/ CoCr-A (Alloy 6) Seat	S31600 w/ CoCr-A Seat & Guide	N05500(2) (K-Monel)	S41600 (416 SST)	
0.5, 0.75, 1, 1.5, & 2	Micro-Flow	4.8	0.1875	9.5	3/8	---	---	2V9269X00A2	---	1V1081X0142	
	Micro-Flute (1 flute)	6.4	0.25					2U8682X0032		1U8445X0032	
	Micro-Flute (3 flutes)	6.4	0.25					2U8684X0032		1U8447X00E2	
	Micro-Form		6.4	0.25	9.5	3/8	15A6500X082	15A6663X022	15A6664X042	15A6500X152	15A6500X092
			9.5	0.375			16A5708X092	16A5713X032	16A5711X022	16A5708X182	16A5708X112
			12.7	0.5			15A6502X072	15A6659X022	15A6660X042	15A6502X102	15A6502X112
			19.1	0.75			16A3335X112	16A3337X042	16A3339X022	16A3335X212	16A3335X132
	Micro-Form		6.4	0.25	12.7	1/2 x 3/8	---	---	15A6664X022	---	15A6500X252
			9.5	0.375			---	---	16A5711X042		16A5708X132
			12.7	0.5			15A6502X162	15A6659X082	15A6660X082		15A6502X152
			19.1	0.75			16A3335X142	16A3337X032	16A3339X092		16A3335X182
	Quick Opening		25.4	1	9.5	3/8	---	15A6516X022	15A6517X022	---	15A6490X092
				12.7	1/2 x 3/8	---	---	---	---	15A6490X072	
Linear		25.4	1	9.5	3/8	15A6470X092	---	15A6615X022	---	15A6470X102	
				12.7	1/2 x 3/8	15A6470X072	---	15A6615X032	---	15A6470X122	
Equal Percentage		25.4	1	9.5	3/8	15A6480X102	15A6634X042	15A6635X022	15A6480X152	15A6480X112	
				12.7	1/2 x 3/8	15A6480X202	15A6634X072	15A6635X042	---	15A6480X172	
1.5	Quick Opening	38.1	1.5	9.5	3/8	15A6492X102	15A6520X032	15A6521X022	---	15A6492X082	
	Linear	38.1	1.5	9.5	3/8	15A6472X132	---	15A6619X022	---	15A6472X072	
	Equal Percentage	38.1	1.5	9.5	3/8	15A6482X102	15A6638X032	15A6639X022	---	15A6482X112	
2	Quick Opening	50.8	2	12.7	1/2	15A6494X082	---	15A6525X022	---	15A6494X072	
	Linear	50.8	2	12.7	1/2	15A6474X132	---	15A6623X022	---	15A6474X072	
	Equal Percentage	50.8	2	12.7	1/2	15A6484X072	15A6642X042	15A6643X032	15A6484X102	15A6484X112	
3	Quick Opening	50.8	2	12.7	1/2	---	---	---	---	15A6494X092	
	Linear	50.8	2	12.7	1/2	15A6474X172	---	---	---	15A6474X152	
	Equal Percentage	50.8	2	12.7	1/2	15A6484X152	---	15A6643X062	---	15A6484X172	
	Quick Opening	76.2	3	12.7	1/2	15A6496X082	---	15A6529X022	---	15A6496X072	
	Linear	76.2	3	12.7	1/2	15A6476X092	---	15A6627X022	---	15A6476X082	
	Equal Percentage	76.2	3	12.7	1/2	15A6486X082	15A6646X022	15A6647X032	---	15A6486X062	
4	Equal Percentage	50.8	2	12.7	1/2	---	15A6642X082	---	---	15A6484X182	
	Quick Opening	101.6	4	12.7	1/2	---	---	---	---	15A6498X072	
	Linear	101.6	4	12.7	1/2	15A6478X072	---	---	---	15A6478X062	
	Equal Percentage	101.6	4	12.7	1/2	15A6488X112	15A6650X022	15A6651X022	---	15A6488X072	

1. Valve stem connection.
2. Monel materials in hydrofluoric acid service require special options. Contact your Fisher sales office for assistance.

Key 3*, 26* Seat Ring Retainer and Bushing Assembly(1) (2)

VALVE SIZE, INCH	SEAT RING RETAINER/BUSHING MATERIAL			
	CB7Cu-1/S17400 (17-4PH SST)	CF8M/R30006 (316 SST/Alloy 6)	M35-1/N05500(3) (Monel/K-Monel)	
0.5, 0.75, & 1	25A6683X062	25A6683X072	25A6683X172	
1.5	25A6685X072	25A6685X082	25A6685X142	
2	Full	25A6687X062	25A6687X112	25A6687X192
	Restricted	25A6687X092	25A6687X132	25A6687X182
3	25A6689X152	25A6689X132	25A6689X142	
4	Full	35A6691X062	35A6691X082	35A6691X092
	Restricted	35A6691X102	17A4161X082	35A6691X112

1. Seat ring retainer (only) part numbers are listed in the parts list on page 23.
2. Micro-Flow and Micro-Flute constructions do not use bushings.
3. Monel materials in hydrofluoric acid service require special options. Contact your Fisher sales office for assistance.

Key 7* Stem (for use with Group 1 Actuators)

VALVE SIZE, INCH	STEM DIAMETER		STEM MATERIAL		
	mm	Inch	S31600	N05500	Nitronic 50 (NACE)
0.5, 0.75, 1, 1.5	9.5	3/8	1U388835162	10A8823XA22	1U3888X0222
	12.7	1/2	1U388935162	1U3889X0012	1U3889X0042
	12.7 x 9.5	1/2 x 3/8	1U530935162	1U530946222	1U5309X0082
2	12.7	1/2	1U388935162	1U3889X0012	1U3889X0042
	12.7 X 9.5	1/2 X 3/8	1U530935162	1U530946222	1U5309X0082
	19.1	3/4	1U226535162	1U226550192	1U2265X0042
3	12.7	1/2	1K586935162	10A8840XH32	1K5869X0102
	19.1	3/4	10A9265XJ62	1U226550192	1U2265X0042
4 (restricted capacity trim)	12.7	1/2	1J320535162	1J3205X0062	1J3205X0072
	19.1	3/4	1U230835162	1U230847492	1U2308X0072
4 (full capacity trim)	12.7	1/2	1K586935162	10A8840XH32	1K5869X0102
	19.1	3/4	1U226535162	1U226550192	1U2265X0042

Key 8* Pin

VALVE SIZE, INCH	VALVE PLUG STYLE	VSC ⁽¹⁾		PIN MATERIAL	
		mm	Inch	S31600 (316 SST)	N04400 (Monel) ⁽²⁾
0.5 thru 2	Micro-Flow & Micro-Flute w/ metal seats	9.5	3/8	1B599235072	1B599240032
	Micro-Flute w/comp seats & Micro-Form	9.5 12.7	3/8 1/2	1B599335072 1D5423X00B2	1B5993X00B2 1D5423X0012
0.5 thru 1.5	Linear, Equal Percentage & Quick Opening	9.5	3/8	1B599335072	1B5993X00B2
		12.7	1/2	1D5423X00B2	1D5423X0012
2	Linear, Equal Percentage & Quick Opening (full cap)	12.7	1/2	1B599835072	1B599840032
		19.1	3/4	1B813635072	1B8136X0102
3	All	9.5	3/8	1B599335072	1B5993X00B2
		12.7	1/2	1D5423X00B2	1D5423X0012
4	Full Capacity	12.7	1/2	1B599835072	1B5998X00C2
		19.1	3/4	1B813635072	1B8136X0102
4	Restricted	12.7	1/2	1B599335072	1B5993X00B2
		19.1	3/4	1F723635072	1B813640032

1. Valve stem connection.

2. Monel materials in hydrofluoric acid service require special options. Contact your Fisher sales office for assistance.

Instruction Manual

Form 5118
April 2005

EZ Valve

Key 9* Seat Ring (non-vaned) for Metal Seats

VALVE SIZE, INCH	PORT DIA		S31600 (316 SST)	S31600 w/ CoCr-A (ALLOY 6) SEAT	S31600 w/ CoCr-A SEAT & BORE	N05500 ⁽¹⁾ (K-MONEL)	S41600 (416 SST)
	mm	Inch					
0.5, 0.75, and 1	4.8	0.1875	1V108335072	2V626250332	25A5710X012	1V108346222	1V108346172
	6.4	0.25	1U285235072	2U855946052	25A5711X012	1U285246222	1U285246172
	9.5	0.375	1U285335072	2U856046052	1U2853X0012	1U285346222	1U285346172
	12.7	0.5	1U285435072	2U856146052	26A0651X012	1U825446222	1U285446172
	19.1	0.75	1U285535072	2U856246052	---	1U2855X0092	1U285546172
	25.4	1	1U285635072	2U856346052	---	1U285646222	1U285646172
1.5	4.8	0.1875	15A6512X012	25A8564X012	25A6536X012	15A6512X042	15A6512X052
	6.4	0.25	15A6513X012	15A6537X012	25A6539X012	15A6513X042	15A6513X052
	9.5	0.375	17A6075X012	27A6076X012	27A6079X012	17A6075X042	17A6075X052
	12.7	0.5	15A6514X012	15A6538X012	26A0653X012	15A6514X042	15A6514X052
	19.1	0.75	16A3350X012	26A3351X012	26A3352X012	16A3350X042	16A3350X052
	25.4	1	15A6515X012	15A6654X012	---	15A6515X042	15A6515X052
	38.1	1.5	15A6504X012	15A6655X012	---	15A6504X042	15A6504X052
2	4.8	0.1875	15A6692X012	25A8565X012	25A6696X012	15A6692X042	15A6692X052
	6.4	0.25	15A6693X012	25A6698X012	25A6697X012	15A6693X042	15A6693X052
	9.5	0.375	17A4091X022	27A6080X012	27A6081X012	17A4091X052	17A4091X012
	12.7	0.5	15A6694X012	25A6699X012	26A0656X012	15A6694X042	15A6694X052
	19.1	0.75	16A3353X012	26A3354X012	26A3355X012	16A3353X042	16A3353X052
	25.4	1	15A6695X012	25A1085X012	---	15A6695X042	15A6695X052
	50.8	2	15A6505X012	15A6656X012	---	15A6505X042	15A6505X052
3	50.8	2	25A5713X012	25A5714X012	---	25A5713X042	25A5713X052
	76.2	3	15A6506X012	15A6657X012	---	15A6506X042	15A6506X052
4	50.8	2	25A5715X012	25A5716X012	---	25A5715X042	25A5715X052
	101.6	4	15A6507X012	15A6658X012	---	15A6507X042	15A6507X052

1. Monel materials in hydrofluoric acid service require special options. Contact your Fisher sales office for assistance.

Key 9* Seat Ring (vaned) for Metal Seats⁽¹⁾

VALVE SIZE, INCH	PORT DIA		CF8M (316 SST)	CF8M w/ CoCr-A (ALLOY 6) SEAT	CA15 (410 SST) ⁽²⁾
	mm	Inch			
0.5, 0.75, and 1	19.1	0.75	37B8773X012	38B0600X012	37B8773X022
	25.4	1	37B8771X012	38B0601X012	37B8771X022
1.5	25.4	1	37B9001X012	38B0602X012	37B9001X022
	38.1	1.5	37B8999X012	38B0603X012	37B8999X022
2	25.4	1	37B8765X012	38B0604X012	37B8765X022
	50.8	2	37B8763X012	38B0605X012	37B8763X022
3	50.8	2	37B9009X012	38B0606X012	37B9009X022
	76.2	3	37B9007X012	38B0607X012	37B9007X022
4	50.8	2	37B8781X012	38B0608X012	37B8781X022
	101.6	4	37B8779X012	38B0609X012	37B8779X022

1. Fisher recommends that the Performance+ vaned seat ring be used for non-viscous, flow-up, liquid applications.
2. Vaned seat ring material is CA15 (410 SST) which is cast equivalent of S41600 (416 SST).

Key 9* Seat Ring (non-vaned) for Composition Seats

VALVE SIZE, INCH	PORT DIAMETER		S31600 (316 SST)	N05500 ⁽¹⁾ (K-MONEL)	S41600 (416 SST)
	mm	Inch			
0.5, 0.75, & 1	6.4	0.25	13A5872X012	13A5872X062	13A5872X022
	9.5	0.375	13A5873X012	13A5873X062	13A5873X032
1.5	6.4	0.25	16A3467X012	16A3467X042	16A3467X052
	9.5	0.375	17A6078X012	17A6078X042	17A6078X052
2	6.4	0.25	16A3468X012	16A3468X042	16A3468X052
	9.5	0.375	17A6077X012	17A6077X042	17A6077X052

1. Monel materials in hydrofluoric acid service require special options. Contact your Fisher sales office for assistance.

Key 10* Bonnet Gasket
 Key 12* Spiral Wound Gasket
 Key 13* Seat Ring Gasket
 Key 25* Shim

Valve Size, Inch	Key Number	Gasket Set 2 ⁽¹⁾	Gasket Set 3 ⁽¹⁾	Gasket Set 4 ⁽¹⁾
0.5 - 0.75 & 1	Set	RGASKETX162	10A8170X042	---
	10	1R2859X0042	10A8163X012	1R2859X0042
	12	1R286099442	10A8184X012	1R286099292
	13	1R2862X0062	10A8177X012	1R2862X0062
	25	16A1936X012	16A1936X022	16A1936X022
1.5	Set	RGASKETX172	10A8171X032	---
	10	1R3101X0032	10A8164X012	1R3101X0032
	12	1R309999442	10A8185X012	1R309999292
	13	1R3098X0052	10A8178X012	1R3098X0052
	25	16A1937X012	16A1937X022	16A1937X022
2	Set	RGASKETX182	10A8172X032	---
	10	1R3299X0042	10A8165X012	1R3299X0042
	12	1R329799442	10A8186X012	1R329799292
	13	1R3296X0042	10A8179X042	1R3296X0042
	25	16A1938X012	16A1938X022	16A1938X022
3	Set	RGASKETX202	10A8174X032	---
	10	1R3484X0042	10A8167X012	1R3484X0042
	12	1R348299442	10A8188X012	1R348299292
	13	1R3481X0052	10A8181X032	1R3481X0052
	25	16A1940X012	16A1940X022	16A1940X022
4	Set	RGASKETX212	--- ⁽²⁾	---
	10	1R3724X0042	10A8168X012	1R3724X0042
	12	1R372299442	10A8189X012	1R372299292
	13	1J5047X0062	10A8182X032	1J5047X0062
	25	16A1941X012	16A1941X022	16A1941X022

1. See table below for description of gasket sets.
 2. Consult your Fisher sales office for gasket set part number.

Gasket Selection Criteria

Gasket Set	Seat Ring Gasket	Bonnet Gasket	Spiral Wound Gasket	Shim	Temperature Capabilities
2 ⁽¹⁾	316 SST/graphite flat sheet	316 SST/graphite flat sheet	N06600 (Inconel)/graphite	S31600	-198 to 593°C (-325 to 1100°F)
3	PTFE-coated N04400 (Monel)	PTFE-coated N04400	N04400/PTFE	N04400	-73 to 149°C (-100 to 300°F)
4	316 SST/graphite flat sheet	316 SST/graphite flat sheet	N04400/composition	N04400	-73 to 232°C (-100 to 450°F)

1. FGM gasket set.

Instruction Manual

Form 5118
April 2005

EZ Valve

Key 26* Bushing

Valve Size, Inch	S17400 (17-4PH SST)	R30006 (Alloy 6)	N05500 (K-Monel) ⁽¹⁾
0.5, 0.75, & 1	15A6508X012	15A6508X022	15A6508X052
1.5	15A7511X012	15A7511X022	15A7511X052
2 (rest. port)	15A6509X012	15A6509X022	15A6509X052
2 (full port)	15A6510X012	15A6510X022	15A6510X052
3	15A7491X012	15A7491X022	15A7491X052
4 (rest. port)	15A5712X012	15A5712X022	15A5712X052
4 (full port)	15A6511X012	15A6511X022	15A6511X052

1. Monel materials in hydrofluoric acid service require special options. Contact your Fisher sales office for assistance.

Key 27* Valve Plug Guide (composition seat only)

VALVE PLUG	VALVE STEM CONNECTION		PORT DIA		MATERIAL			
	mm	Inch	mm	Inch	S31600 (316 SST)	N05500 ⁽¹⁾ (K-Monel)	S41600 (416 SST)	S31600 w/CoCr-A (Alloy 6)
Micro-Flute	9.5	3/8	6.4	0.25	16A3440X012	16A3440X042	- - -	19A5814X012
Micro-Form	9.5	3/8	6.4	0.25	16A3440X012	16A3440X042	16A3440X052	19A5814X012
			9.5	0.375	16A5703X012	16A5703X042	16A5703X052	19A5815X012
			12.7	0.5	16A3445X012	16A3445X042	16A3445X052	17A7250X012
	12.7	1/2	19.1	0.75	26A3449X012	26A3449X042	26A3449X052	28A8115X012
			9.5	0.375	16A5707X012	16A5707X042	16A5707X052	19A5815X012
			12.7	0.5	16A3446X012	16A3446X042	16A3446X052	19A5817X012
19.1	0.75	26A3450X012	26A3450X042	26A3450X052	29A5812X012			
Equal Percentage	9.5	3/8	25.4	1	26A3453X012	26A3453X042	26A3453X052	29A5806X012
	12.7	1/2	25.4	1	26A3454X012	26A3454X042	26A3454X052	29A5807X012
	9.5	3/8	38.1	1.5	26A3457X012	26A3457X042	26A3457X052	28A1253X012
	12.7	1/2	50.8	2	26A3460X012	26A3460X042	26A3460X052	29A5813X012
	12.7	1/2	76.2	3	26A3470X012	26A3470X042	26A3470X052	29A5811X012
	19.1	3/4	76.2	3	26A3471X012	26A3471X042	26A3471X052	29A5810X012
	12.7	1/2	102	4	26A3463X012	26A3463X042	26A3463X052	29A5808X012
	19.1	3/4	102	4	26A3464X012	26A3464X042	26A3464X052	29A5809X012

1. Monel materials in hydrofluoric acid service require special options. Contact your Fisher sales office for assistance.

Key 30* Tip

VALVE SIZE, INCH	VALVE PLUG	PORT DIA		VALVE STEM CONNECTION		MATERIAL			
		mm	Inch	mm	Inch	S31600 (316 SST)	Alloy 6	N05500 ⁽¹⁾ (K-Monel)	S41600 (416 SST)
0.5, 0.75, 1, 1.5, & 2	Micro-Flute (1 flute)	6.4	0.25	9.5	3/8	---	13A5863X032	13A5863X042	---
	Micro-Flute (3 flutes)					---	13A5865X032	13A5865X022	---
	Micro-Form	6.4	0.25	9.5	3/8	13A6160X022	---	13A6160X062	13A6160X012
		9.5	0.375			16A5704X012	---	16A5704X042	16A5704X052
		12.7	0.5			1R9537X0022	---	1R9537X0062	1R9537X0012
		19.1	0.75			1R9540X0012	---	1R9540X0072	1R9540X0042
		9.5	0.375	16A5704X012	---	16A5704X042	16A5704X052		
		12.7	0.5	12.7	1/2	1R9537X0022	---	1R9537X0062	1R9537X0012
	19.1	0.75			1R9540X0012	---	1R9540X0072	1R9540X0042	
	Equal Percentage	25.4	1	9.5 & 12.7	3/8 & 1/2	1R953835072	---	1R9538X0032	1R9538X0012
		38.1	1.5	9.5	3/8	16A3458X012	---	16A3458X042	16A3458X052
		50.8	2	12.7	1/2	12A3889X012	---	12A3889X042	12A3889X052
3	Equal Percentage	76.2	3	12.7 & 19.1	1/2 & 3/4	16A3469X012	---	16A3469X042	16A3469X052
4	Equal Percentage	101.6	4	12.7 & 19.1	1/2 & 3/4	12A3760X022	---	12A3760X012	12A3760X052

1. Monel materials in hydrofluoric acid service require special options. Contact your Fisher sales office for assistance.

Group 1 Actuators

54, 71, & 90 mm (2-1/8, 2-13/16, & 3-9/16 Inch) Yoke Boss
350—except 90 mm (3-9/16 inch) yoke boss 472 & 473 585C & 585CR 603 & 1B 644 & 645 655 657 & 667—76 mm (3-inch) max travel 1008—except 90 mm (3-9/16 inch) yoke boss with 51 mm (2-inch) travel

ENVIRO-SEAL, HIGH-SEAL, easy-e, and Fisher are marks owned by Fisher Controls International LLC, a member of the Emerson Process Management business division of Emerson Electric Co. The Emerson logo is a trademark and service mark of Emerson Electric Co. All other marks are the property of their respective owners. This product may be covered by one or more of the following patents: 5,129,625; 5,131,666; 5,056,757; 5,230,498; and 5,299,812 or under pending patents.

The contents of this publication are presented for informational purposes only, and while every effort has been made to ensure their accuracy, they are not to be construed as warranties or guarantees, express or implied, regarding the products or services described herein or their use or applicability. We reserve the right to modify or improve the designs or specifications of such products at any time without notice.

Neither Emerson, Emerson Process Management, nor Fisher assume responsibility for the selection, use or maintenance of any Fisher product. Responsibility for proper selection, use and maintenance of any Fisher product remains solely with the purchaser and end-user.

Emerson Process Management

Fisher

Marshalltown, Iowa 50158 USA

Cernay 68700 France

Sao Paulo 05424 Brazil

Singapore 128461

www.Fisher.com

