

Stickle

Steam Specialties Co. Inc.



BULLETIN NO. 862
REV. 7-88

**The STICKLE
Trouble Shooting
Magnetrol
P68-P71**

Stickle

Steam Specialties Co. Inc.

2215 Valley Avenue • Indianapolis, Indiana 46218-4388
Phone 317-636-6563 Fax 317-637-3249

The STICKLE

Trouble Shooting

P68 & P71 Magnetrols

Reference Sheet B-4166

NO OUTPUT SIGNAL

- A. Be sure Supply Gauge (D) is at 20 PSI.
- B. Moving Bar (K) up & down Output Gauge (N) should go from 0-20 PSI. If no response proceed as follows:
 1. Depress Clean Out Pin (A) on Relay (C) .
 2. Pinch Nozzle Line (F) shut with fingers. This should give 20 PSI output signal (If not proceed with steps 3-4).
 3. Tighten Relay Cover Screws (B) .
 4. Remove Clearout Pin Assembly (A) and inspect for broken wire in orifice.
 5. Inspect Flapper Face (P) for dirt accumulation
 6. Make sure Zero Adjustment Screw (H) is set per calibration Sheet B-4165.

OUTPUT SIGNAL WILL NOT DECREASE

1. Check Zero Adjustment Screw (H) for correct setting.
2. Remove screw on top of Nozzle Block (G) and clean orifice with wire.
3. Remove Cleanout Pin Assembly (A) and inspect for broken orifice disc.

ADJUST AND CALIBRATE IN ACCORDANCE WITH SHEET B-4165

B-4166

P68-P71 Magnetrol Controller

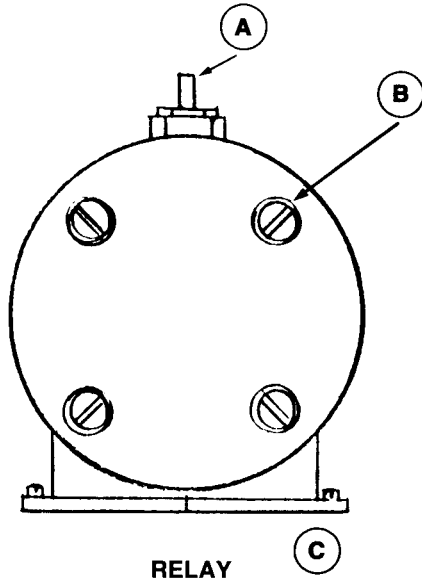

FIG. 6

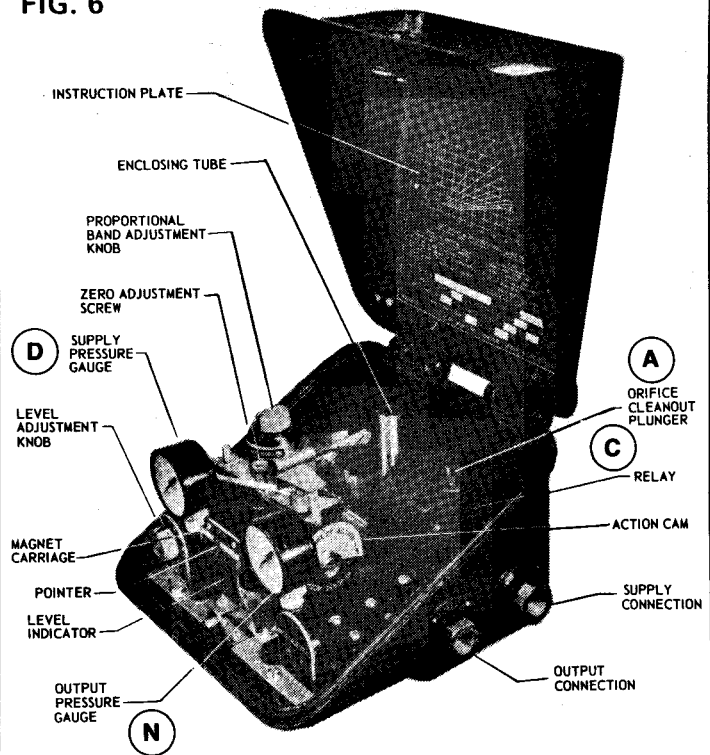

FIG. 8

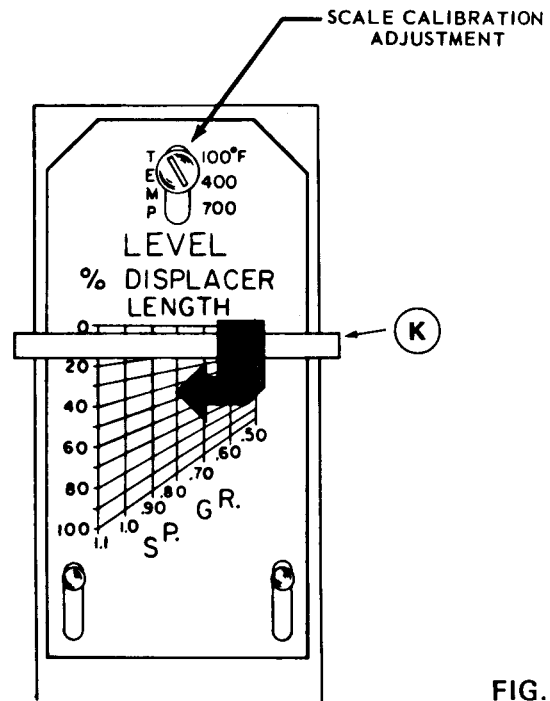
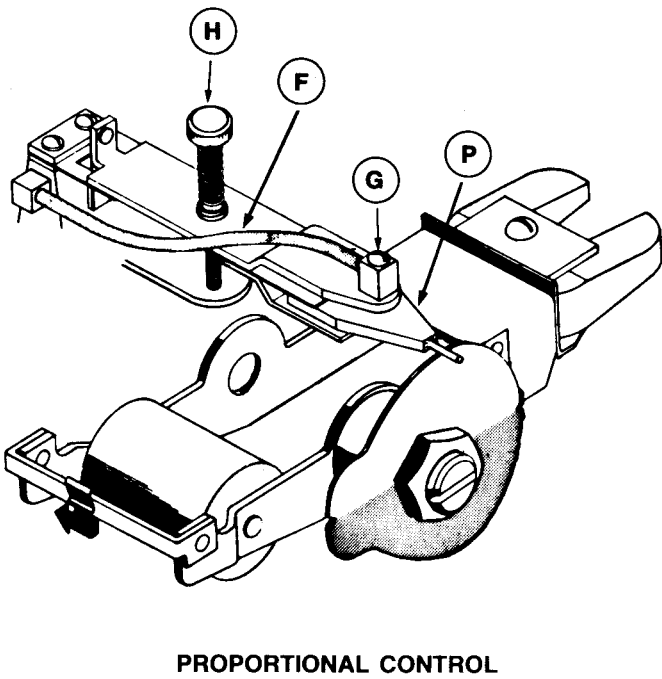
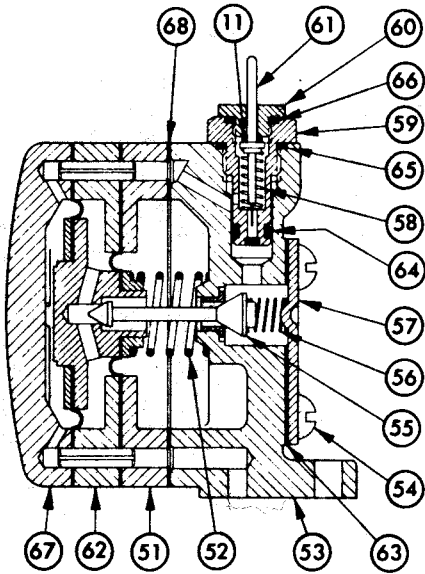

FIG. 9

RELAY ASSEMBLY (ITEMS 15 and 16)



ITEM	DESCRIPTION	Replacement Assembly ②	
67	Cover	Refer To Relay Kit Listed Above	
50	8 - 32 x 1-1/8 R.H. Cover Screws		
51	Center Ring		
52	Bias Spring		
53	Relay Housing Assembly		
54	8 - 32 x 5/16 Pan Hd. Screws		
55	Check		
56	Check Spring		
57	Check Plate		
58	Wiper Spring		
59	Wiper Body & Orifice Assembly		
60	Wiper Bushing		
61	Wiper		
62	Center Section (w/Diaphragms)		Relay Gasket Kit 89-3611-001
63	Check Plate Gasket		
64	"O" Ring, Wiper Body (Small)		
65	"O" Ring, Wiper Body (Large)		
66	"O" Ring, Wiper Bushing		
11	"O" Ring, Wiper		
68	Chamber Gasket		

⑤① Cover Screws (Not Shown)

FIG. 14



2215 Valley Avenue • Indianapolis, Indiana 46218-4388
 Phone 317-636-6563 Fax 317-637-3249